

# MANICURE & PEDICURE BITS

美甲美足磨头

惠 惠 惠  
而 而 而  
顺 顺 顺

2023  
|  
2024

Carbide Nail Bits

Ceramic Nail Bits

**SC Bits**

Diamond Bits

Pedicure Bits

钨钢磨头

陶瓷磨头

超切削磨头

电镀金刚石磨头

足部磨头

 **WILSON**<sup>®</sup>  
PRECISION TOOL

 **WILSON**<sup>®</sup>  
PRECISION TOOL

 **WILSON**<sup>®</sup>  
PRECISION TOOL



**WILSON**  
PRECISION TOOL

Cutting tools may shatter; please wear safety glasses

# CONTENTS

## 目录

Carbide Nail Bits 钨钢磨头 03

---

SC Bits 超切削磨头 25

---

Diamond Bits 电镀金刚石磨头 31

---

Ceramic Nail Bits 陶瓷磨头 39

---

Pedicure Bits 足部磨头 49

---

Nail Accessories 美甲附件 54

---

Reference Form 产品索引 58

---



# INSTRUCTION OF USE

## 使用说明

1. 确认产品包装完整性。  
Ensure that the package of the product is intact.
2. 使用前请仔细检查产品，任何损坏或变形都会导致产品断裂。  
Examine the product before use. Any damage or deformation may cause the breakage of the products.
3. 请佩戴护目镜。  
Safety glasses are recommended.
4. 确保产品被固定于筒夹或手柄中。  
Make sure that the product is inserted all the way into the handpiece and securely fastened.

为达到最佳使用效果：

For the best result:

1. 在产生任何接触之前，产品必须在推荐的速度下旋转。  
Product must be rotated at recommended speed before any contact is made.
2. 无须施加很大的压力。  
Apply low contact pressure and brush stroke.
3. 避免横向压力。  
Avoid using the products with a heavy transverse cutting pressure.

# SAFETY RULES

## 安全须知

1. 确保产品被稳定地安装在手柄或筒夹中。  
Ensure that the product is securely gripped in the handpiece or the collet.
2. 请不要使用已经产生磨损的产品。  
Do not use worn-out products.
3. 请不要施加过大的压力。  
Do not apply excessive pressure on the products.
4. 避免接触产品的尖锐部位。  
Avoid to touch the sharp part of the products.

# Shank Length: 柄长(L<sub>2</sub>)

Standard Shank  
标准柄

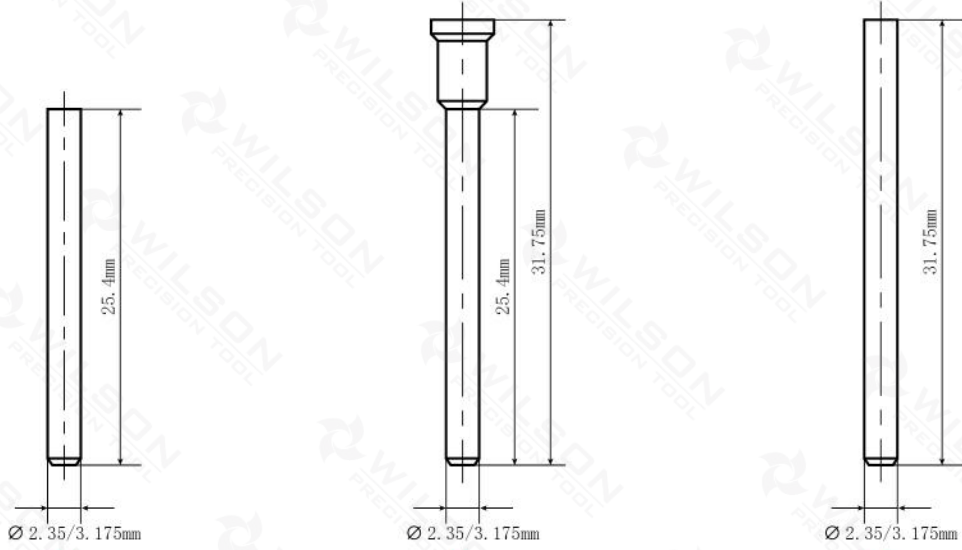

a

b

c



A

B

C

Long Shank  
长柄

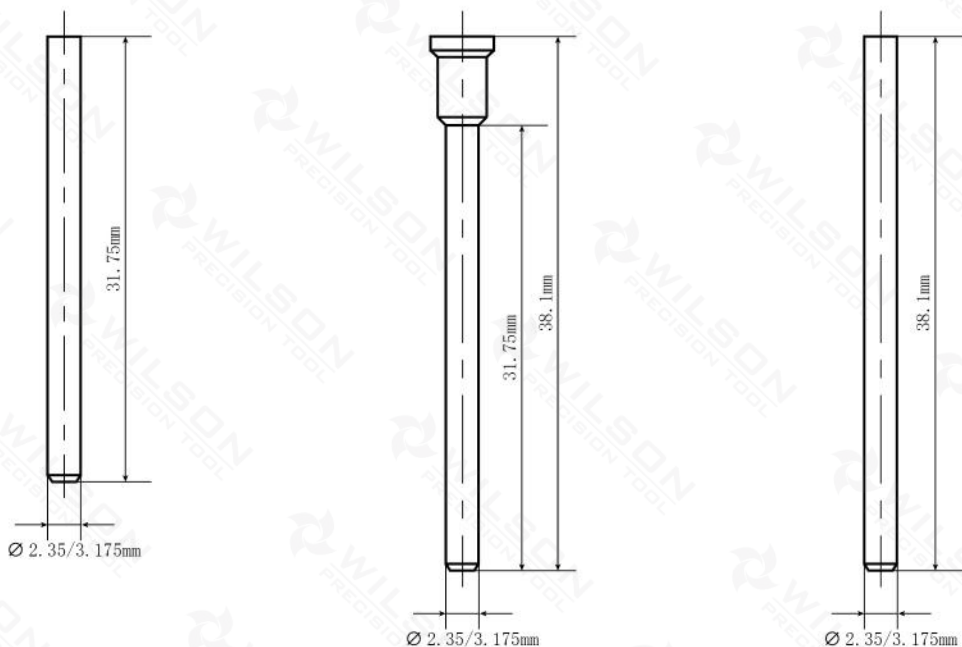

钨  
钢  
磨  
头



Carbide Nail Bits

# Carbide Nail Bits

钨钢磨头

# Carbide Bits Specifications

## 美甲钨钢磨头规格

Coarseness 齿密度	Ring 色圈
Super 五倍 Coarse 极粗齿	5XC
Ultra 四倍 Coarse 特粗齿	4XC
Triple 三倍 Coarse 特粗齿	3XC
Double 两倍 Coarse 特粗齿	XXC
Extra 特粗齿	XC
Coarse 粗齿	C
Medium 标准齿	M
Fine 细齿	F
Extra 特细齿	XF
Double 两倍 Fine 特细齿	XXF
Triple 三倍 Fine 极细齿	3XF

**Flute Diameter  
刃径**

- With Cut
- Round Cut
- No Cut
- No Cut

**Shank Diameter  
柄径**

- 2.35mm
- 3.175mm

For Left Hand  
左手

For Right Hand  
右手

For Left and Right Hand  
左、右手

For Left and Right Hand  
左、右手  
Reduced capacity for left hand  
左手使用时切削力下降

Left Hand Single Rotation  
左手单向打磨

Right Hand Single Rotation  
右手单向打磨

Left and Right Hand Dual Rotation  
左、右手双向打磨

**Coating  
镀层**

None	Silver	Gold	Blue Nano	TIN	Rosy Gold	Rain-bow	Purple	DLC	DC
无镀层	银色	金色	蓝纳米	氮化钛	玫瑰金	彩色	紫色	类金刚石	金刚石

\* 本样本册所有编号默认列示无镀层，除特殊规格外。  
\* All numbers in this catalogue are listed as non-plated by default, except for special specifications.

\* 特殊规格磨头，均可定制。

\* Grinding heads of special specifications can be customized.

## Large Barrel Bits 6.60mm直筒平头

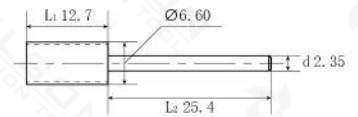

			密度 Coarseness	Surer Coarse 5XC	Ultra Coarse 4XC	Triple Coarse 3XC	Double Coarse 2XC	Extra Coarse 1XC	Coarse C	Medium M	Fine F	Extra Fine XF	Double Fine XXF
订单编号 Order No.	1100322 1100007 1100008 1100009 1100010 1100011 1100012 1100013 1100014 1100015 1100016												

## Large Barrel Bits (Chamfer) 6.60mm直筒平头 (倒角)

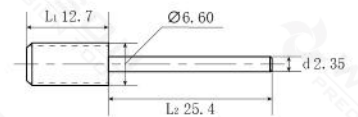

			密度 Coarseness	Surer Coarse 5XC	Ultra Coarse 4XC	Triple Coarse 3XC	Double Coarse 2XC	Extra Coarse 1XC	Coarse C	Medium M	Fine F	Extra Fine XF	Double Fine XXF
订单编号 Order No.	1100698 1100431 1100432 1100433 1100434 1100435 1100436 1100437 1100438 1100439 1100440												

## Crystal Large Barrel Bits 6.60mm带钻直筒平头

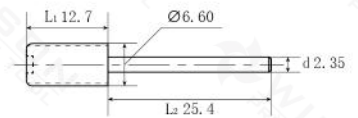

			密度 Coarseness	Ultra Coarse 4XC	Triple Coarse 3XC	Double Coarse 2XC	Extra Coarse 1XC	Coarse C	Medium M	Fine F	Extra Fine XF
订单编号 Order No.	1100411 1100412 1100413 1100414 1100415 1100416 1100417 1100418 1100419										

## Crystal Large Barrel Bits (R Cut) 6.60mm带钻直筒平头 (R角)

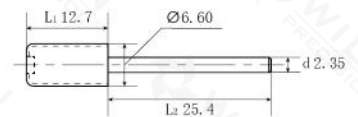

			密度 Coarseness	Ultra Coarse 4XC	Triple Coarse 3XC	Double Coarse 2XC	Extra Coarse 1XC	Coarse C	Medium M	Fine F	Extra Fine XF
订单编号 Order No.	1100401 1100402 1100403 1100404 1100405 1100406 1100407 1100408 1100409										



## Windmill Crystal Large Barrel Bits (Chamfer)

6.60mm直筒风车钻 (倒角)

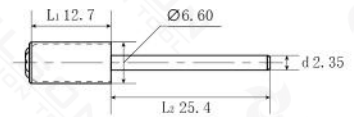

No Cut 									
	密度 Coarseness	Triple Coarse 3XC	Double Coarse XXC	Extra Coarse XC	Coarse C	Medium M	Fine F	Extra Fine XF	Double Fine XXF
订单编号 Order No.	1102085	1102086	1102087	1102088	1102089	1102090	1101806	1101807	1101808

## Large Barrel Smooth Top Bits

6.60mm直筒光头

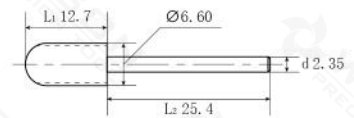

No Cut 									
	密度 Coarseness	Ultra Coarse 4XC	Triple Coarse 3XC	Double Coarse XXC	Extra Coarse XC	Coarse C	Medium M	Fine F	Extra Fine XF
订单编号 Order No.	1100165	1100166	1100167	1100168	1100055	1100056	1100057	1100169	1100170

## Large Rounded Top Bits

6.60mm直筒球头

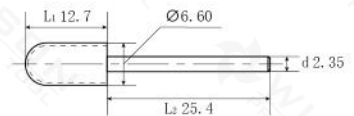

Round Cut 									
	密度 Coarseness	Ultra Coarse 4XC	Triple Coarse 3XC	Double Coarse XXC	Extra Coarse XC	Coarse C	Medium M	Fine F	Extra Fine XF
订单编号 Order No.	1100179	1100180	1100181	1100182	1100067	1100068	1100069	1100183	1100184

## Small Barrel Bits

5.35mm直筒平头

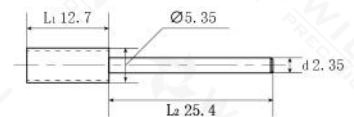

With Cut 											
	密度 Coarseness	Surer Coarse 5XC	Ultra Coarse 4XC	Triple Coarse 3XC	Double Coarse XXC	Extra Coarse XC	Coarse C	Medium M	Fine F	Extra Fine XF	Double Fine XXF
订单编号 Order No.	1100321	1100020	1100021	1100022	1100023	1100024	1100025	1100026	1100027	1100028	1100029

### Small Barrel Bits (Chamfer)

5.35mm直筒平头 (倒角)

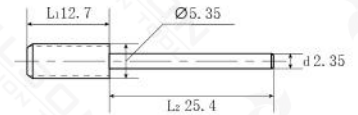

No Cut 											
	密度 Coarseness	Surer Coarse 5XC	Ultra Coarse 4XC	Triple Coarse 3XC	Double Coarse 2XC	Extra Coarse 1XC	Coarse C	Medium M	Fine F	Extra Fine XF	Double Fine XXF
订单编号 Order No.	1100699	1100700	1100701	1100702	1100703	1100704	1100705	1100706	1100707	1100708	1100709

### Crystal Small Barrel Bits

5.35mm带钻直筒平头

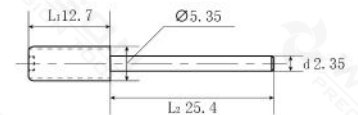

No Cut 									
	密度 Coarseness	Ultra Coarse 4XC	Triple Coarse 3XC	Double Coarse 2XC	Extra Coarse 1XC	Coarse C	Medium M	Fine F	Extra Fine XF
订单编号 Order No.	1100586	1100587	1100588	1100589	1100590	1100591	1100592	1100593	1100594

### Crystal Small Barrel Bits (R Cut)

5.35mm带钻直筒平头 (R角)

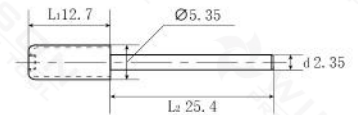

Round Cut 									
	密度 Coarseness	Ultra Coarse 4XC	Triple Coarse 3XC	Double Coarse 2XC	Extra Coarse 1XC	Coarse C	Medium M	Fine F	Extra Fine XF
订单编号 Order No.	1100576	1100577	1100578	1100579	1100580	1100581	1100582	1100583	1100584

### Small Barrel Smooth Top Bits

5.35mm直筒光头

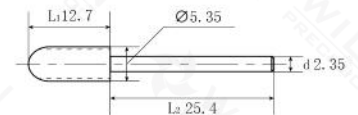

No Cut 									
	密度 Coarseness	Ultra Coarse 4XC	Triple Coarse 3XC	Double Coarse 2XC	Extra Coarse 1XC	Coarse C	Medium M	Fine F	Extra Fine XF
订单编号 Order No.	1100172	1100173	1100174	1100175	1100061	1100062	1100063	1100176	1100177

### Small Rounded Top Bits 5.35mm直筒球头

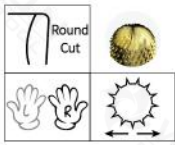
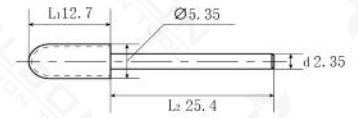

密度 Coarseness	Ultra Coarse 4XC	Triple Coarse 3XC	Double Coarse 2XC	Extra Coarse XC	Coarse C	Medium M	Fine F	Extra Fine XF	Double Fine XXF
订单编号 Order No.	1100186	1100187	1100188	1100189	1100073	1100074	1100075	1100190	1100191

### Big Barrel Bits 8.0mm直筒平头

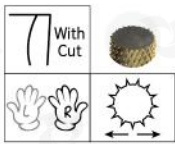
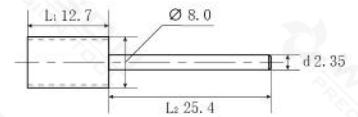

密度 Coarseness	Coarse C	Medium M	Fine F
订单编号 Order No.	1100004	1100005	1100006

### Super Big Barrel Bits 9.5mm直筒平头

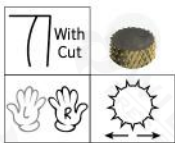
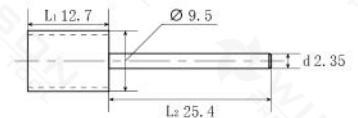

密度 Coarseness	Coarse C	Medium M	Fine F
订单编号 Order No.	1100001	1100002	1100003

### Small Pink & White Bits 5.35mm端齿

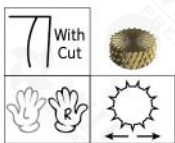
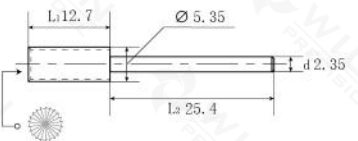

密度 Coarseness	Coarse C	Medium M	Fine F
订单编号 Order No.	1100049	1100050	1100051

### Large Pink & White Bits 6.60mm端齿

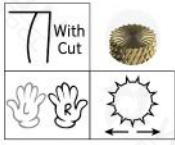
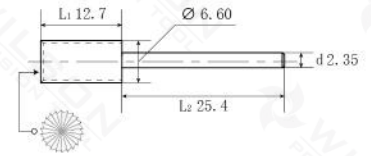

密度 Coarseness	Extra Coarse XC	Coarse C	Medium M	Fine F
订单编号 Order No.	1100335	1100043	1100044	1100045

### Big Pink & White Bits 8.0mm端齿

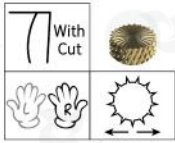
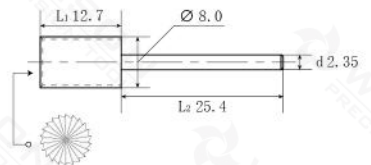

密度 Coarseness	Coarse C	Medium M	Fine F
订单编号 Order No.	1100040	1100041	1100042

### Super Big Pink & White Bits 9.5mm端齿

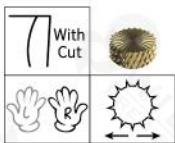
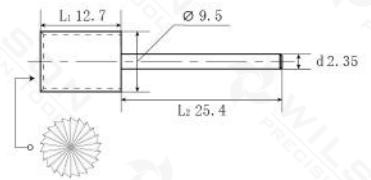

密度 Coarseness	Coarse C	Medium M	Fine F
订单编号 Order No.	1100037	1100038	1100039



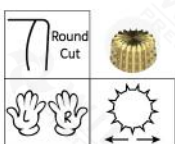
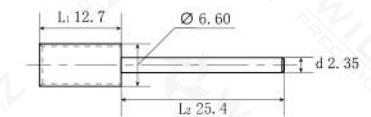





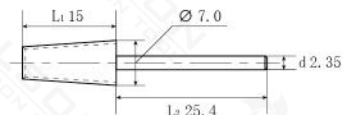

### 3 in 1 Bits (Straight Cut) 三合一 (直槽齿)



密度 Coarseness	Triple Coarse 3XC	Double Coarse 2XC	Extra Coarse XC	Coarse C	Medium M	Fine F	Extra Fine XF
订单编号 Order No.	1100865	1100866	1100867	1100868	1100869	1100870	1100871



**7.0mm 5 in 1 Bits (Straight Cut)**  
7.0mm五合一 (直槽齿)

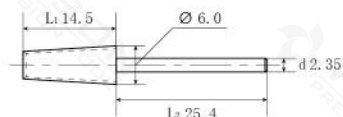

 Round Cut 								
	Triple Coarse 3XC	Double Coarse XXC	Extra Coarse XC	Coarse C	Medium M	Fine F	Extra Fine XF	Double Fine XXF
密度 Coarseness								
订单编号 Order No.	1100858	1100859	1100860	1100861	1100862	1100863	1100864	1100895

**6.0mm 5 in 1 Bits (Straight Cut)**  
6.0mm五合一 (直槽齿)



 Round Cut 								
	Triple Coarse 3XC	Double Coarse XXC	Extra Coarse XC	Coarse C	Medium M	Fine F	Extra Fine XF	Double Fine XXF
密度 Coarseness								
订单编号 Order No.	1100955	1100956	1100957	1100958	1100959	1100960	1100961	1100962

**5.2mm 5 in 1 Bits (Straight Cut)**  
5.2mm五合一 (直槽齿)

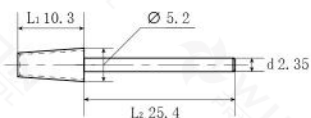

 Round Cut 					
	Extra Coarse XC	Coarse C	Medium M	Fine F	Extra Fine XF
密度 Coarseness					
订单编号 Order No.	1100678	1100679	1100680	1100681	1100682

**5.2mm Mini 5 in 1 Bits (Straight Cut)**  
5.2mm迷你五合一 (直槽齿)

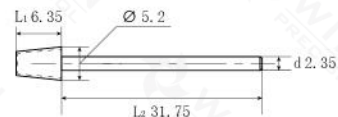

 Round Cut 					
	Extra Coarse XC	Coarse C	Medium M	Fine F	Extra Fine XF
密度 Coarseness					
订单编号 Order No.	1101684	1101685	1101686	1101687	1101688

### 7.0mm 5 in 1 Plus Bits (Cross Cut)

7.0mm长刃五合一（交叉齿）

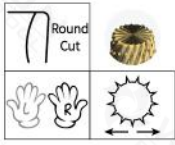
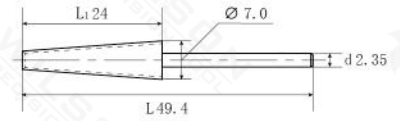

密度 Coarseness	Triple Coarse 3XC	Double Coarse XXC	Extra Coarse XC	Coarse C	Medium M	Fine F	Extra Fine XF	Double Fine XXF
订单编号 Order No.	1303129	1303130	1303131	1303132	1303133	1303134	1303135	1303136

### 7.0mm 5 in 1 Bits (Cross Cut)

7.0mm五合一（交叉齿）

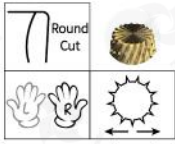
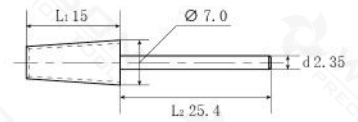

密度 Coarseness	Triple Coarse 3XC	Double Coarse XXC	Extra Coarse XC	Coarse C	Medium M	Fine F	Extra Fine XF	Double Fine XXF
订单编号 Order No.	1100910	1100911	1100912	1100913	1100914	1100915	1100916	1100917

### 6.0mm 5 in 1 Bits (Cross Cut)

6.0mm五合一（交叉齿）

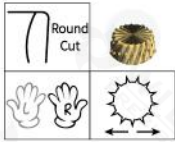
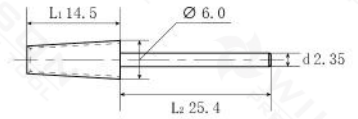

密度 Coarseness	Triple Coarse 3XC	Double Coarse XXC	Extra Coarse XC	Coarse C	Medium M	Fine F	Extra Fine XF	Double Fine XXF
订单编号 Order No.	1100997	1100998	1100999	1101000	1101001	1101002	1101003	1101004

### 5.2mm 5 in 1 Bits (Cross Cut)

5.2mm五合一（交叉齿）

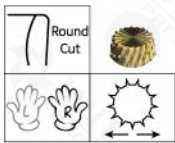
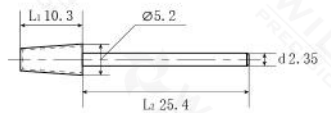

密度 Coarseness	Extra Coarse XC	Coarse C	Medium M	Fine F	Extra Fine XF
订单编号 Order No.	1101058	1101059	1101060	1101061	1101062

### 4.0mm 5 in 1 Bits (Cross Cut)

4.0mm五合一 (交叉齿)

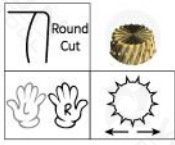
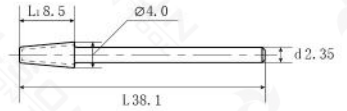

密度 Coarseness	Extra Coarse XC	Coarse C	Medium M	Fine F	Extra Fine XF
订单编号 Order No.	1302383	1302384	1302385	1302386	1302387

### 6.0mm 5 in 1 Pro Bits

6.0mm五合一-Pro

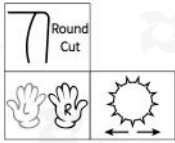
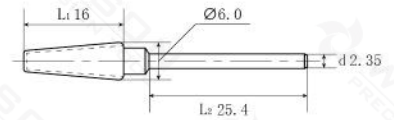

密度 Coarseness	Double Coarse XXC + Medium M + Double Fine XXF	Extra Coarse XC + Medium M + Triple Fine 3XF
订单编号 Order No.	1102381	1101932

### 6.0mm 5 in 1 - S Bits

6.0mm五合一组合

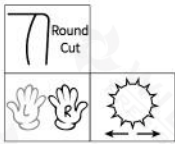
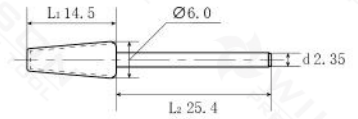

密度 Coarseness	Extra Coarse XC + Double Fine XXF	Medium M + Double Fine XXF
订单编号 Order No.	1101887	1101888

### Tapered Barrel Bits

5.2mm锥形平头

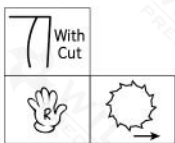
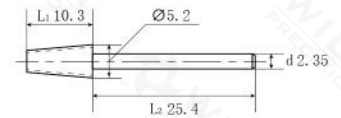

密度 Coarseness	Extra Coarse XC	Coarse C	Medium M	Fine F
订单编号 Order No.	1100926	1100088	1100089	1100090

## Large Tapered Barrel Bits 6.6mm锥形平头

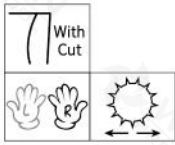
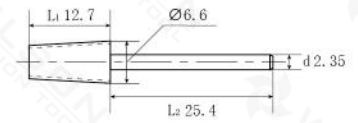

密度 Coarseness	Coarse C	Medium M	Fine F	Extra Fine XF
订单编号 Order No.	1100276	1100277	1100278	1100279

## Small Cone Bits 3.1mm锥形球头

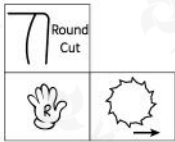
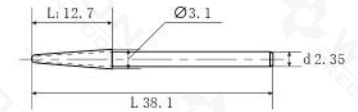

密度 Coarseness	Coarse C	Medium M	Fine F
订单编号 Order No.	1300106	1300107	1300108

## Small Cone Bits (2 Way) 3.1mm锥形球头 (双向)

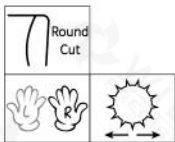
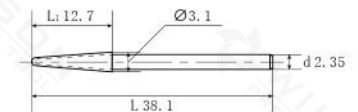

密度 Coarseness	Coarse C	Medium M	Fine F
订单编号 Order No.	1302155	1302156	1302157

## Cone Bits 4.0mm锥形球头

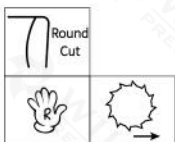
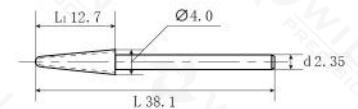

密度 Coarseness	Extra Coarse XC	Coarse C	Medium M	Fine F	Extra Fine XF
订单编号 Order No.	1300226	1300100	1300101	1300102	1300238



**Cone Bits (2 Way)**  
4.0mm锥形球头 (双向)

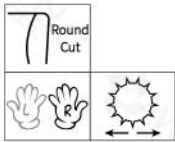
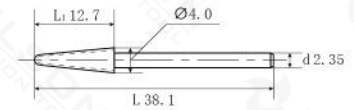

密度 Coarseness	Extra Coarse XC	Coarse C
订单编号 Order No.	1302149	1302150

**Safety Bits**  
5.2mm锥形球头

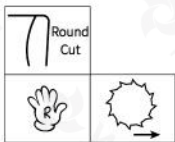
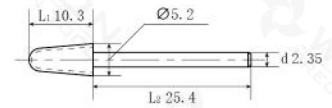

密度 Coarseness	Coarse C	Medium M	Fine F
订单编号 Order No.	1100094	1100095	1100096

**Safety Bits (2 Way)**  
5.2mm锥形球头 (双向)

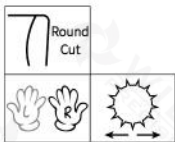
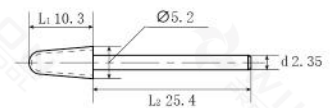

密度 Coarseness	Medium M	Fine F
订单编号 Order No.	1100464	1100465

**Large Safety Bits**  
6.0mm锥形球头

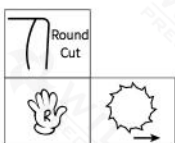
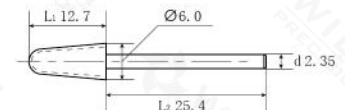

密度 Coarseness	Coarse C	Medium M	Fine F
订单编号 Order No.	1100229	1100230	1100231

## Volcano Bits 7.0mm火山形

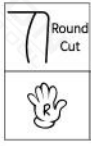
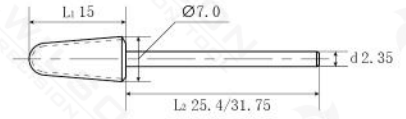

密度 Coarseness		Triple Coarse 3XC	Double Coarse XXC	Extra Coarse XC	Coarse C	Medium M	Fine F	Extra Fine XF
订单编号 Order No.	Shank a 25.4mm	1100633	1100634	1100524	1100525	1100526	1100527	1100635
	Shank c 31.75mm	1100629	1100630	1100540	1100541	1100542	1100543	1100631

## Volcano Bits (2 Way) 7.0mm火山形 (双向)

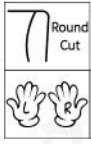
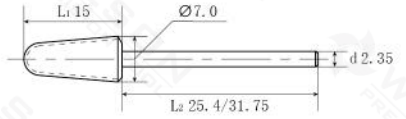

密度 Coarseness		Triple Coarse 3XC	Double Coarse XXC	Extra Coarse XC	Coarse C	Medium M	Fine F	Extra Fine XF
订单编号 Order No.	Shank a 25.4mm	1100648	1100649	1100650	1100651	1100652	1100653	1100654
	Shank c 31.75mm	1100730	1100731	1100732	1100733	1100734	1100735	1100736

## Tornado Bits 7.0mm龙卷风

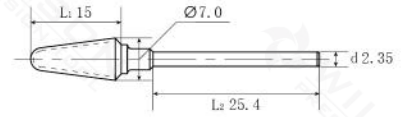

密度 Coarseness		Triple Coarse 3XC	Double Coarse XXC	Extra Coarse XC	Coarse C	Medium M	Fine F
订单编号 Order No.		1170991	1170534	1170536	1170535	1170537	1170538

## Mini Cone Bits 4.0mm小玉米

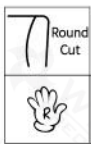
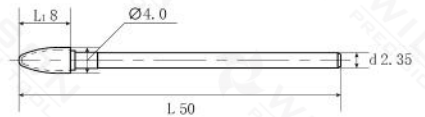

密度 Coarseness		Coarse C	Medium M	Fine F	Extra Fine XF
订单编号 Order No.		1300126	1300127	1300128	1300395

## Large Cone Bits 6.0mm大玉米

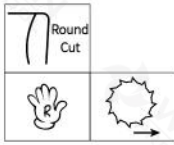
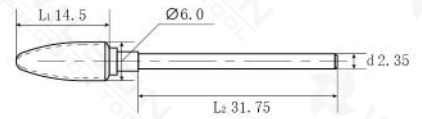

密度 Coarseness	Double Coarse XXC	Extra Coarse XC	Coarse C	Medium M	Fine F	Extra Fine XF
订单编号 Order No.	1100446	1100447	1100119	1100120	1100121	1100122

## Oval Tornado Bits 6.0mm椭圆龙卷风

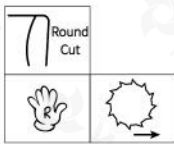
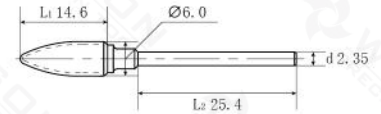

密度 Coarseness	Coarse C	Medium M	Fine F	Extra Fine XF
订单编号 Order No.	1170544	1170545	1170546	1170547

## Typhoon Bits 6.0mm台风形

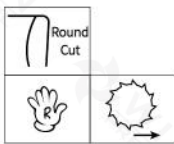
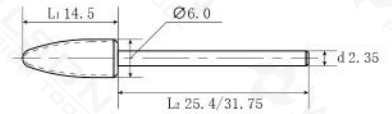

密度 Coarseness		Triple Coarse 3XC	Double Coarse XXC	Extra Coarse XC	Coarse C	Medium M	Fine F	Extra Fine XF
订单编号 Order No.	Shank a 25.4mm	1100873	1100874	1100529	1100530	1100531	1100532	1100875
	Shank c 31.75mm	1100486	1100487	1100488	1100489	1100490	1100491	1100492

## Typhoon Bits (2 Way) 6.0mm台风形 (双向)

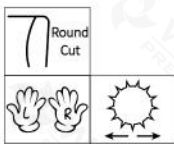
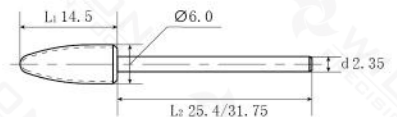

密度 Coarseness		Triple Coarse 3XC	Double Coarse XXC	Extra Coarse XC	Coarse C	Medium M	Fine F	Extra Fine XF
订单编号 Order No.	Shank a 25.4mm	1100638	1100639	1100640	1100641	1100642	1100643	1100644
	Shank c 31.75mm	1100750	1100751	1100752	1100753	1100754	1100755	1100756

### Flame Bits 6.0mm火炬状

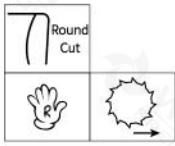
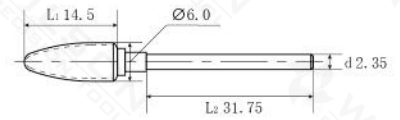

密度 Coarseness	Extra Coarse XC	Coarse C	Medium M	Fine F
订单编号 Order No.	1100710	1100132	1100133	1100134

### Upgrade Flame Bits 6.0mm火炬状 (升级版)

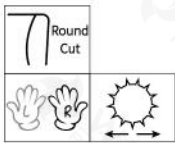
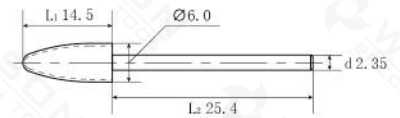

密度 Coarseness	Coarse C	Medium M	Fine F	Extra Fine XF
订单编号 Order No.	1100467	1100468	1100469	1100470

### Long Flame Bits 6.0mm长刃火炬状

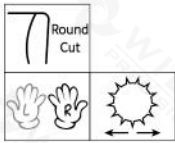
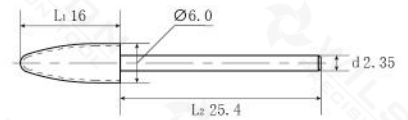

密度 Coarseness	Triple Coarse 3XC	Double Coarse 2XC	Extra Coarse XC	Coarse C	Medium M	Fine F
订单编号 Order No.	1100512	1100513	1100514	1100515	1100516	1100517

### Buffer Bits (Diamond Cut) 本甲刻磨 (钻石齿)

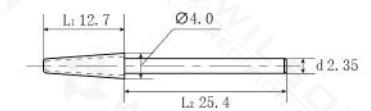
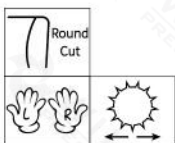
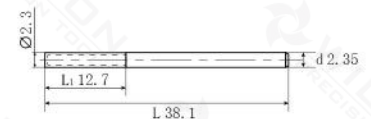

刃径 Flute Diameter	2.3mm	4.0mm	5.35mm
订单编号 Order No.	1300504	1300575	1100251

**Buffer Bits (Spiral Cut)**  
无痕本甲刻磨 (螺旋齿)

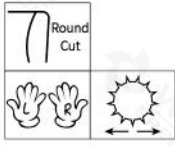
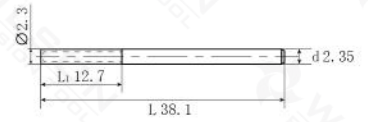

刃径 Flute Diameter	2.3mm
订单编号 Order No.	1301748

**Sharp Point Bits**  
小锥形球头

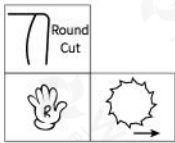
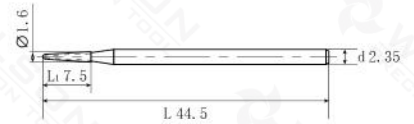

密度 Coarseness	Coarse C	Medium M	Fine F
订单编号 Order No.	1300112	1300113	1300114

**Round Bits**  
小直筒球头

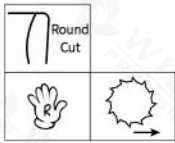
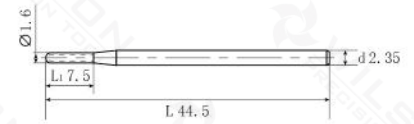

密度 Coarseness	Coarse C	Medium M	Fine F	Extra Fine XF
订单编号 Order No.	1300079	1300080	1300081	1300711

**Upgrade Round Bits**  
小直筒球头 (升级版)

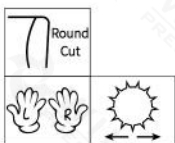
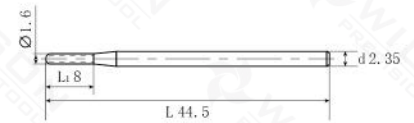

密度 Coarseness	Coarse C	Medium M	Fine F
订单编号 Order No.	1300929	1300930	1300931

## Upgrade Small Cone Bits 3.1mm锥形球头 (升级版)

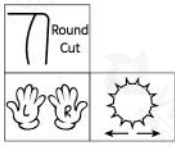
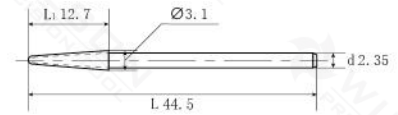

刃径 Flute Diameter	3.1mm
订单编号 Order No.	1302921

## Polygon Bits 多边形磨头

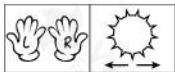

形状 Shape	八边形 Octagon	七边形 Septangle	六边形 Hexagon (Round)	六边形 Hexagon (Sharp)
订单编号 Order No.	1300147	1300712	1300993	1300994

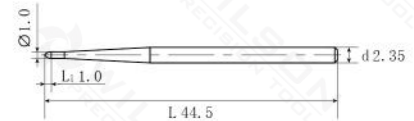
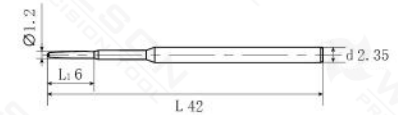

## Flame Polygon Bits 火炬多边形磨头

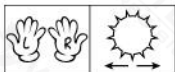

形状 Shape	三角形 Triangle	四边形 Quadrilateral	五边形 Pentagon	六边形 Hexagon	电镀五边形 Pentagon
订单编号 Order No.	1301099	1301100	1301079	1301080	8001234

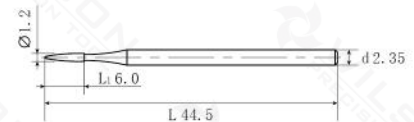

## Mini Polygon Bits 迷你多边形磨头

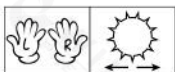

形状 Shape	迷你八边形 Mini Octagon
订单编号 Order No.	1300897

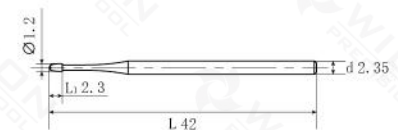

### Sharp Conical Bits (Cross Cut) 长刃尖锥 (交叉齿)

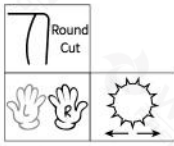
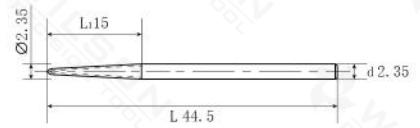

密度 Coarseness	Double Fine XXF	Coarse C + Extra Fine XF
订单编号 Order No.	1301242	1302446

### Sharp Conical Bits (Straight Cut) 长刃尖锥 (直槽齿)

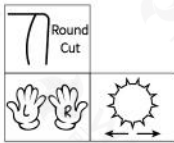

密度 Coarseness	Fine F	Extra Fine XF	Double Fine XXF
订单编号 Order No.	1301719	1301239	1301240

### Sharp Conical – S Bits (Straight Cut) 长刃尖锥组合 (直槽齿)

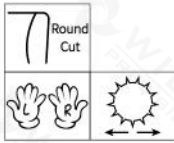
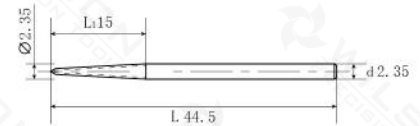

密度 Coarseness	Medium M + Double Fine XXF
订单编号 Order No.	1302450

### Cuticle Clean Bits 角质清洁磨头

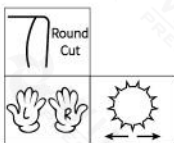
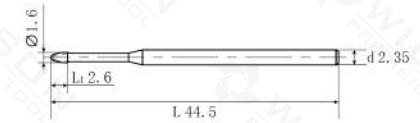



密度 Coarseness	Coarse C	Medium M	Fine F
订单编号 Order No.	1300506	1300507	1300148

## Pear Shape Bits 梨形

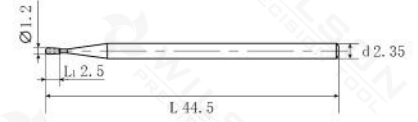
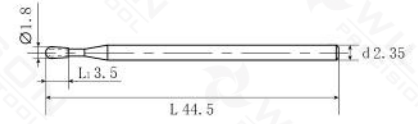
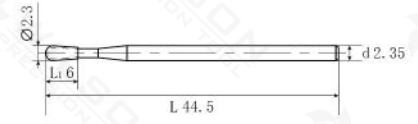
 Round Cut  			
	刃径 Flute Diameter	2.3mm	1.8mm
订单编号 Order No.	1300250	1301203	1301681



## 2.3mm Inverted Conical (R Cut) 2.3mm倒锥R角

 Round Cut  	
	密度 Coarseness
订单编号 Order No.	1302176

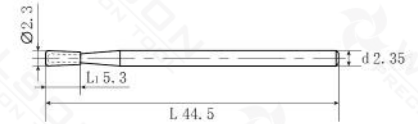

## Remove Ornaments Bits 卸钻

 Round Cut  	
	密度 Coarseness
订单编号 Order No.	1300400

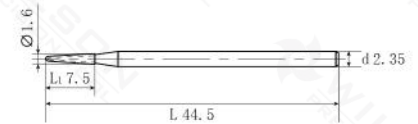

## Upgrade Remove Ornaments Bits 卸钻 (升级版)

 Round Cut  	
	密度 Coarseness
订单编号 Order No.	1300398





## Under Nail Cleaner Bits 针状平头

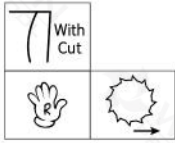
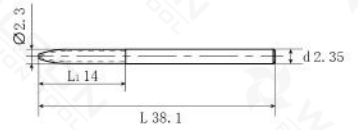

密度 Coarseness	Coarse C	Medium M	Fine F	Extra Fine XF
订单编号 Order No.	1300141	1300142	1300143	1300391

## Under Nail Cleaner Bits (2 Way) 针状平头 (双向)

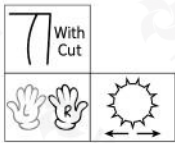
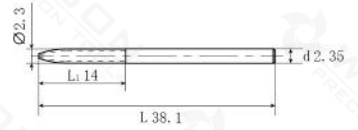

密度 Coarseness	Coarse C	Medium M	Fine F
订单编号 Order No.	1300951	1300952	1300953

## Cylindrical 针状-修后缘超硬胶

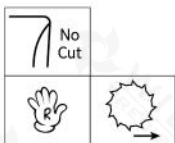
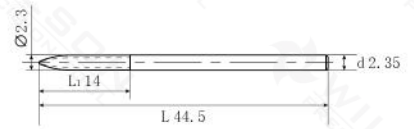

密度 Coarseness	Extra Coarse XC
订单编号 Order No.	1302806

## Pierce Bits 打孔钻

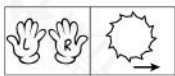
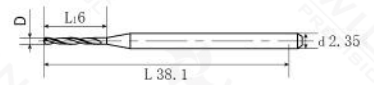

刃径 Flute Diameter	1.4mm	1.2mm	1.0mm	0.8mm	0.6mm
订单编号 Order No.	1301653	1301654	1301655	1301656	1301657

### Tip Bottom Drill Bits 点位钻

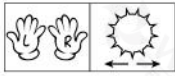
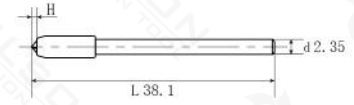

点钻深度 Depth H	1.2mm	1.0mm	0.8mm	0.6mm	0.4mm
订单编号 Order No.	1341643	1341644	1341645	1341646	1341647

### Ball Shape Bits (Cross Cut) 球形 (交叉齿)

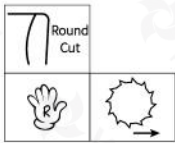
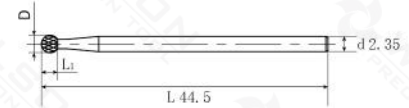

刃径 Flute Diameter	2.3mm	2.7mm	3.0mm
订单编号 Order No.	1300884	1300715	1300716

### Ball Shape Bits (Plain Cut) 球形 (右旋齿)

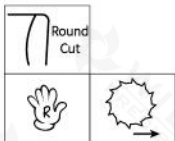

刃径 Flute Diameter	2.3mm	3.0mm	2.7mm	3.0mm
订单编号 Order No.	1300553	1300554	1300713	1300714

### 2-Week Backfill Bits 二周钻

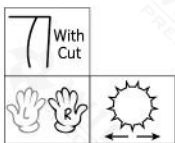
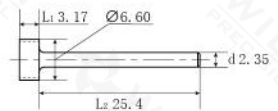

密度 Coarseness	Coarse C	Medium M	Fine F
订单编号 Order No.	1100082	1100083	1100084

### 4-Week Backfill Bits 四周钻

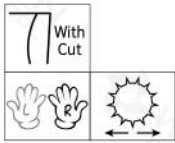
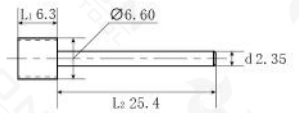

密度 Coarseness	Coarse C	Medium M	Fine F
订单编号 Order No.	1100085	1100086	1100087

### Tapered Backfill Bits 四周顺锥

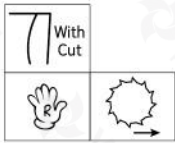
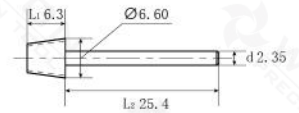

密度 Coarseness	Coarse C	Medium M	Fine F
订单编号 Order No.	1100138	1100139	1100140

### 6.0mm 5 in 1 Backfill Bits 6.0mm五合一倒锥

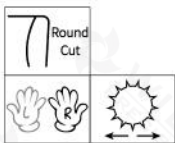
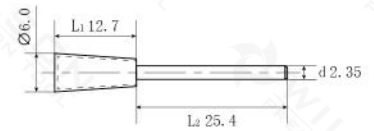

密度 Coarseness	Coarse C	Medium M	Fine F	Extra Fine XF
订单编号 Order No.	1101753	1101754	1101755	1101756

### Inverted Backfill Bits 四周倒锥

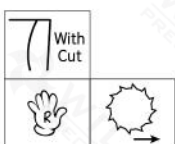
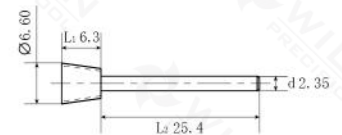

密度 Coarseness	Coarse C	Medium M	Fine F
订单编号 Order No.	1100135	1100136	1100137

# SC Bits Introduction

## 超切削磨头介绍

随着超硬胶和水晶甲的流行，超切削磨头应运而生，简称SC超切削磨头，在提高切削力的同时，拥有更平稳的打磨手感。

With the popularity of super-hard nail gel and acrylic nail, the super-cutting grinding heads came into being, referred to as SC bits, which have a smoother grinding experience while increasing the cutting efficiency.

### 超切削齿 Super Cut



### 常规齿 Normal Cut

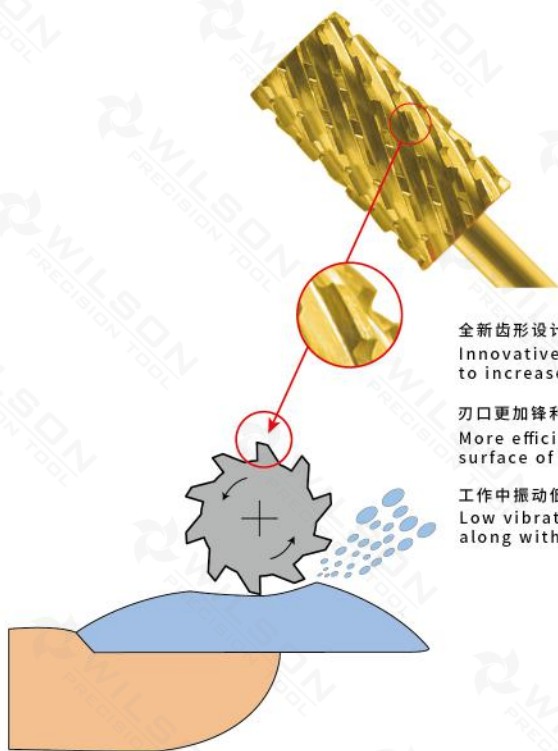

全新齿形设计，增加使用寿命。  
Innovative cutting edge geometries to increase the service life.

刃口更加锋利，提高打磨面光滑度。  
More efficient cutting for better surface of workpieces.

工作中震动低，打磨更稳定。  
Low vibration during operation along with a smoother cutting.

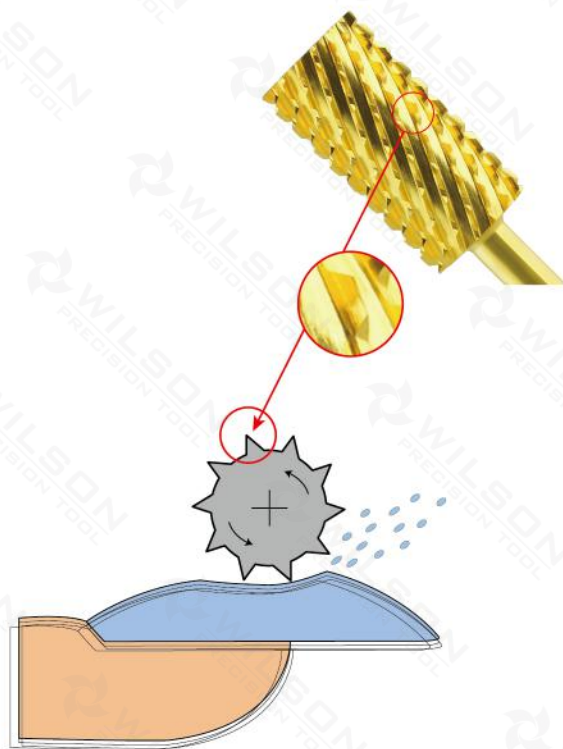

适用于卸除水晶、光疗等超硬胶。  
Suitable for trimming hard gel and acrylic etc.

# SC Bits

## 超切削磨头

# SC Bits Specifications

## 超切削磨头规格

Coarseness 齿密度	Ring 色圈
Triple 三倍 Coarse 特粗齿	3XC
Double 两倍 Coarse 特粗齿	XXC
Extra 特粗齿 Coarse	XC
Coarse 粗齿	C
Medium 标准齿	M

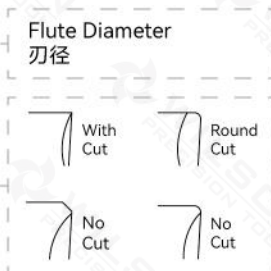

Shank Diameter  
柄径  
2.35mm  
3.175mm

- For Left Hand  
左手
- For Right Hand  
右手
- Left Hand Single Rotation  
左手单向打磨
- Right Hand Single Rotation  
右手单向打磨

Coating  
镀层

None	Silver	Gold	Blue Nano	TiN	Rosy Gold	Rain-bow	Purple	DLC	DC
无镀层	银色	金色	蓝纳米	氮化钛	玫瑰金	彩色	紫色	类金刚石	金刚石

\* 本样本册所有编号默认列示无镀层，除特殊规格外。  
\* All numbers in this catalogue are listed as non-plated by default, except for special specifications.

\* 特殊规格磨头，均可定制。  
\* Grinding heads of special specifications can be customized.

**Large Barrel Bits – SC**  
6.60mm直筒平头-SC

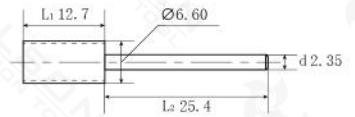

  					
	密度 Coarseness	Triple Coarse 3XC	Double Coarse XXC	Extra Coarse XC	Coarse C
订单编号 Order No.	1101072	1101073	1101074	1101075	1101076

**Large Barrel Bits (Chamfer) – SC**  
6.60mm直筒平头 (倒角)-SC

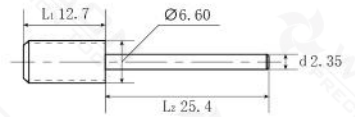

  					
	密度 Coarseness	Triple Coarse 3XC	Double Coarse XXC	Extra Coarse XC	Coarse C
订单编号 Order No.	1102130	1102131	1102132	1102133	1102134

**Windmill Crystal Large Barrel Bits – SC**  
6.60mm直筒风车镶钻-SC

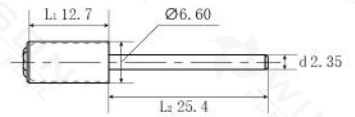

  					
	密度 Coarseness	Triple Coarse 3XC	Double Coarse XXC	Extra Coarse XC	Coarse C
订单编号 Order No.	1101935	1101936	1101937	1101938	1101939

**Large Barrel Smooth Top Bits – SC**  
6.60mm直筒光头-SC

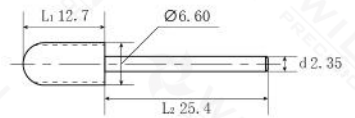

  					
	密度 Coarseness	Triple Coarse 3XC	Double Coarse XXC	Extra Coarse XC	Coarse C
订单编号 Order No.	1101082	1101083	1101084	1101085	1101086

**Small Barrel Bits – SC**  
5.35mm直筒平头-SC

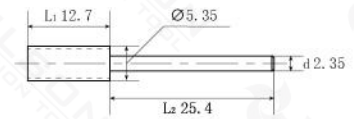

	With Cut							
密度 Coarseness				Triple Coarse 3XC	Double Coarse XXC	Extra Coarse XC	Coarse C	Medium M
订单编号 Order No.				1101244	1101245	1101246	1101247	1101248

**Small Barrel Bits (Chamfer) – SC**  
5.35mm直筒平头 (倒角) -SC

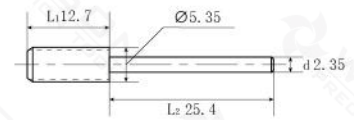

	No Cut							
密度 Coarseness				Triple Coarse 3XC	Double Coarse XXC	Extra Coarse XC	Coarse C	Medium M
订单编号 Order No.				1102160	1102161	1102162	1102163	1102164

**Small Barrel Smooth Top Bits – SC**  
5.35mm直筒光头-SC

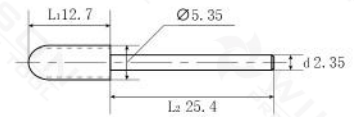

	No Cut							
密度 Coarseness				Triple Coarse 3XC	Double Coarse XXC	Extra Coarse XC	Coarse C	Medium M
订单编号 Order No.				1101264	1101265	1101266	1101267	1101268

**7.0mm Tapered Bits (Straight Cut) – SC**  
7.0mm顺锥R角 (直槽齿) -SC

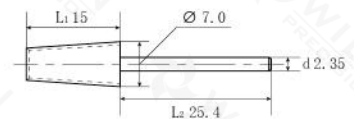

	Round Cut							
密度 Coarseness				Triple Coarse 3XC	Double Coarse XXC	Extra Coarse XC	Coarse C	Medium M
订单编号 Order No.				1100972	1100973	1100974	1100975	1100976



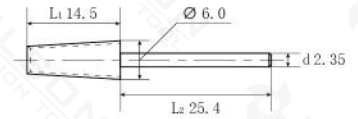

**6.0mm Tapered Bits (Straight Cut) – SC**  
**6.0mm 顺锥R角 (直槽齿) –SC**

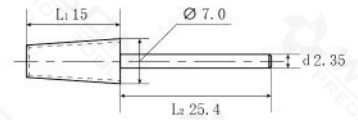

 Round Cut 					
	<b>Triple Coarse 3XC</b>	<b>Double Coarse XXC</b>	<b>Extra Coarse XC</b>	<b>Coarse C</b>	<b>Medium M</b>
<b>密度 Coarseness</b>					
<b>订单编号 Order No.</b>	1101360	1101361	1101362	1101363	1101364

**7.0mm Tapered Bits (Cross Cut) – SC**  
**7.0mm 顺锥R角 (交叉齿) –SC**



 Round Cut 					
	<b>Triple Coarse 3XC</b>	<b>Double Coarse XXC</b>	<b>Extra Coarse XC</b>	<b>Coarse C</b>	<b>Medium M</b>
<b>密度 Coarseness</b>					
<b>订单编号 Order No.</b>	1101035	1101036	1101037	1101038	1101039

**6.0mm Tapered Bits (Cross Cut) – SC**  
**6.0mm 顺锥R角 (交叉齿) –SC**

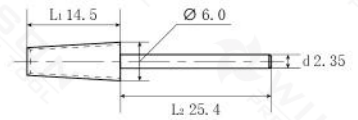

 Round Cut 					
	<b>Triple Coarse 3XC</b>	<b>Double Coarse XXC</b>	<b>Extra Coarse XC</b>	<b>Coarse C</b>	<b>Medium M</b>
<b>密度 Coarseness</b>					
<b>订单编号 Order No.</b>	1101376	1101377	1101378	1101379	1101380





# SC Bits

## 超切削磨头

电镀  
金刚石  
磨头



Diamond Bits

# Diamond Bits

电镀金刚石磨头

# Diamond Bits Specifications

## 美甲电镀金刚石磨头规格

Grit size 颗粒度	Ring 色圈
Extra Fine 380# 特细	Yellow
Fine 320# 细	Red
Medium 170# 中	Blue
Coarse 120# 粗	Green

Flute Diameter  
刃径

Total Length  
总长  
44.5mm

Shank Diameter  
柄径  
2.35mm

For Left and Right Hand  
左、右手

Left and Right Hand  
Dual Rotation  
左、右手双向打磨



\* 特殊规格磨头，均可定制。  
\* Grinding heads of special specifications can be customized.

## Ball Shape 球形





刃径 Flute Diameter		1.0mm	1.6mm	2.1mm	2.3mm	2.5mm	3.1mm	4.0mm	4.5mm	5.0mm	6.0mm
刃长 Flute Length		—									
Grits Size 颗粒度	Coarse C	8000401	8000403	8000405	8000406	8000407	8000408	8000409	8000410	8000411	8000464
	Medium M	8000301	8000303	8000305	8000306	8000307	8000308	8000309	8000310	8000311	8000364
	Fine F	8000201	8000203	8000205	8000206	8000207	8000208	8000209	8000210	8000211	8000264
	Extra Fine XF	8000101	8000103	8000105	8000106	8000107	8000108	8000109	8000110	8000111	8000164

## Cooling – Groove Ball Shape 球形-冷却槽



刃径 Flute Diameter		—	—	2.1mm	2.3mm	2.5mm	3.1mm	4.0mm	4.5mm	5.0mm	6.0mm
刃长 Flute Length		—									
Grits Size 颗粒度	Coarse C	—	—	8005405	8005406	8005407	8005408	8005409	8005410	8005411	8005464
	Medium M	—	—	8005305	8005306	8005307	8005308	8005309	8005310	8005311	8005364
	Fine F	—	—	8005205	8005206	8005207	8005208	8005209	8005210	8005211	8005264
	Extra Fine XF	—	—	8005105	8005106	8005107	8005108	8005109	8005110	8005111	8005164

## Rounded Top Barrel Shape 直筒球头

刃径 Flute Diameter		1.6mm	1.8mm	2.3mm	2.3mm	2.5mm	2.7mm	2.7mm	3.0mm	4.0mm
刃长 Flute Length		7mm	7mm	7mm	12mm	7mm	7mm	12mm	7mm	9mm
Grits Size 颗粒度	Coarse C	8000412	8000413	8000414	8002403	8000415	8000416	8002404	8000417	8000465
	Medium M	8000312	8000313	8000314	8002303	8000315	8000316	8002304	8000317	8000365
	Fine F	8000212	8000213	8000214	8002203	8000215	8000216	8002204	8000217	8000265
	Extra Fine XF	8000112	8000113	8000114	8002103	8000115	8000116	8002104	8000117	8000165

## Cooling – Groove Rounded Top Barrel Shape 直筒球头-冷却槽



刃径 Flute Diameter		1.6mm	1.8mm	2.3mm	2.3mm	2.5mm	2.7mm	2.7mm	3.0mm	4.0mm
刃长 Flute Length		7mm	7mm	7mm	12mm	7mm	7mm	12mm	7mm	9mm
Grits Size 颗粒度	Coarse C	8005412	8005413	8005414	8007403	8005415	8005416	8007404	8005417	8005465
	Medium M	8005312	8005313	8005314	8007303	8005315	8005316	8007304	8005317	8005365
	Fine F	8005212	8005213	8005214	8007203	8005215	8005216	8007204	8005217	8005265
	Extra Fine XF	8005112	8005113	8005114	8007103	8005115	8005116	8007104	8005117	8005165

## Flame Shape 火炬形



刃径 Flute Diameter	1.5mm	1.8mm	1.8mm	2.1mm	2.3mm	2.5mm	2.7mm	
刃长 Flute Length	8mm	5mm	8mm	8mm	8mm	8mm	8mm	
Grits Size 颗粒度	Coarse C	8000419	8001418	8000420	8000421	8000422	8000463	8000423
	Medium M	8000319	8001318	8000320	8000321	8000322	8000363	8000323
	Fine F	8000219	8001218	8000220	8000221	8000222	8000263	8000223
	Extra Fine XF	8000119	8001118	8000120	8000121	8000122	8000163	8000123

## Cooling – Groove Flame Shape 火炬形-冷却槽



刃径 Flute Diameter	—	1.8mm	1.8mm	2.1mm	2.3mm	2.5mm	2.7mm	
刃长 Flute Length	—	5mm	8mm	8mm	8mm	8mm	8mm	
Grits Size 颗粒度	Coarse C	—	8006418	8005420	8005421	8005422	8005463	8005423
	Medium M	—	8006318	8005320	8005321	8005322	8005363	8005323
	Fine F	—	8006218	8005220	8005221	8005222	8005263	8005223
	Extra Fine XF	—	8006118	8005120	8005121	8005122	8005163	8005123

## Barrel Shape 直筒平头



刃径 Flute Diameter	1.2mm	1.4mm	1.4mm	1.6mm	1.8mm	2.1mm	2.3mm	2.7mm	5.0mm	5.5mm	
刃长 Flute Length	7mm	3.5mm	7mm	7mm	7mm	7mm	7mm	7mm	7mm	12.7mm	
Grits Size 颗粒度	Coarse C	8000424	8001403	8000425	8000426	8000427	8000428	8000429	8000430	8000431	8202420
	Medium M	8000324	8001303	8000325	8000326	8000327	8000328	8000329	8000330	8000331	8202320
	Fine F	8000224	8001203	8000225	8000226	8000227	8000228	8000229	8000230	8000231	8202220
	Extra Fine XF	8000124	8001103	8000125	8000126	8000127	8000128	8000129	8000130	8000131	8202120

## Cooling – Groove Barrel Shape 直筒平头-冷却槽



刃径 Flute Diameter	—	1.4mm	1.4mm	1.6mm	1.8mm	2.1mm	2.3mm	2.7mm	5.0mm	5.5mm	
刃长 Flute Length	—	3.5mm	7mm	7mm	7mm	7mm	7mm	7mm	7mm	12.7mm	
Grits Size 颗粒度	Coarse C	—	8006403	8005425	8005426	8005427	8005428	8005429	8005430	8005431	8207420
	Medium M	—	8006303	8005325	8005326	8005327	8005328	8005329	8005330	8005331	8207320
	Fine F	—	8006203	8005225	8005226	8005227	8005228	8005229	8005230	8005231	8207220
	Extra Fine XF	—	8006103	8005125	8005126	8005127	8005128	8005129	8005130	8005131	8207120

## Tapered Shape

顺锥平头

 								
刃径 Flute Diameter		1.4mm	1.6mm	2.3mm	2.5mm	4.0mm	4.0mm	5.4mm
刃长 Flute Length		3.5mm	3.5mm	12mm	7mm	9mm	13mm	11mm
Grits Size 颗粒度	Coarse C	8001417	8000436	8002405	8000437	8000438	8002419	8000468
	Medium M	8001317	8000336	8002305	8000337	8000338	8002319	8000368
	Fine F	8001217	8000236	8002205	8000237	8000238	8002219	8000268
	Extra Fine XF	8001117	8000136	8002105	8000137	8000138	8002119	8000168



## Cooling – Groove Tapered Shape

顺锥平头-冷却槽

 								
刃径 Flute Diameter		1.4mm	1.6mm	2.3mm	2.5mm	4.0mm	4.0mm	5.4mm
刃长 Flute Length		3.5mm	3.5mm	12mm	7mm	9mm	13mm	11mm
Grits Size 颗粒度	Coarse C	8006417	8005436	8007405	8005437	8005438	8007419	8005468
	Medium M	8006317	8005336	8007305	8005337	8005338	8007319	8005368
	Fine F	8006217	8005236	8007205	8005237	8005238	8007219	8005268
	Extra Fine XF	8006117	8005136	8007105	8005137	8005138	8007119	8005168





## Tapered Shape (Round Corner)

顺锥平头(圆角)

 			
刃径 Flute Diameter		2.5mm	4.0mm
刃长 Flute Length		7mm	13mm
Grits Size 颗粒度	Coarse C	8000457	8002409
	Medium M	8000357	8002309
	Fine F	8000257	8002209
	Extra Fine XF	8000157	8002109

## Cooling – Groove Tapered Shape (Round Corner)

顺锥平头(圆角)-冷却槽

 			
刃径 Flute Diameter		2.5mm	4.0mm
刃长 Flute Length		7mm	13mm
Grits Size 颗粒度	Coarse C	8005457	8007409
	Medium M	8005357	8007309
	Fine F	8005257	8007209
	Extra Fine XF	8005157	8007109









## Conical Round Shape

锥形圆头

												
刃径 Flute Diameter				1.2mm	1.4mm	1.6mm	1.8mm	2.1mm	2.3mm	2.3mm	4.0mm	4.0mm
刃长 Flute Length				8mm	8mm	8mm	8mm	8mm	8mm	10mm	8mm	13mm
Grits Size 颗粒度	Coarse C			8000439	8000440	8000441	8000442	8000443	8000444	8002412	8000447	8002413
	Medium M			8000339	8000340	8000341	8000342	8000343	8000344	8002312	8000347	8002313
	Fine F			8000239	8000240	8000241	8000242	8000243	8000244	8002212	8000247	8002213
	Extra Fine XF			8000139	8000140	8000141	8000142	8000143	8000144	8002112	8000147	8002113

## Cooling – Groove Conical Round Shape

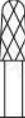
锥形圆头-冷却槽

										
刃径 Flute Diameter				1.6mm	1.8mm	2.1mm	2.3mm	2.3mm	4.0mm	—
刃长 Flute Length				8mm	8mm	8mm	8mm	10mm	8mm	—
Grits Size 颗粒度	Coarse C			8005441	8005442	8005443	8005444	8007412	8005447	—
	Medium M			8005341	8005342	8005343	8005344	8007312	8005347	—
	Fine F			8005241	8005242	8005243	8005244	8007212	8005247	—
	Extra Fine XF			8005141	8005142	8005143	8005144	8007112	8005147	—







## Bud Shape

芽形

							
刃径 Flute Diameter				3.0mm	4.0mm	5.0mm	6.0mm
刃长 Flute Length				12mm	12mm	12mm	20mm
Grits Size 颗粒度	Coarse C			8000448	8000449	8000450	8002418
	Medium M			8000348	8000349	8000350	8002318
	Fine F			8000248	8000249	8000250	8002218
	Extra Fine XF			8000148	8000149	8000150	8002118

## Cooling – Groove Bud Shape

芽形-冷却槽

							
刃径 Flute Diameter				3.0mm	4.0mm	5.0mm	6.0mm
刃长 Flute Length				12mm	12mm	12mm	20mm
Grits Size 颗粒度	Coarse C			8005448	8005449	8005450	8007418
	Medium M			8005348	8005349	8005350	8007318
	Fine F			8005248	8005249	8005250	8007218
	Extra Fine XF			8005148	8005149	8005150	8007118

## Pear Shape

梨形

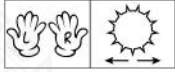

刃径 Flute Diameter		1.2mm	1.8mm	2.3mm	3.4mm
刃长 Flute Length		3mm	3.5mm	5mm	7.7mm
Grits Size 颗粒度	Coarse C	8000462	8001420	8001421	8000467
	Medium M	8000362	8001320	8001321	8000367
	Fine F	8000262	8001220	8001221	8000267
	Extra Fine XF	8000162	8001120	8001121	8000167

## Inverted Shape

倒锥平头

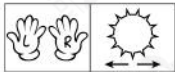

刃径 Flute Diameter		2.3mm	2.3mm	1.6mm
刃长 Flute Length		1mm	2.6mm	4mm
Grits Size 颗粒度	Coarse C	8001416	8001428	8001419
	Medium M	8001316	8001328	8001319
	Fine F	8001216	8001228	8001219
	Extra Fine XF	8001116	8001128	8001119

## Long Bullet Shape

长刃弧形圆头

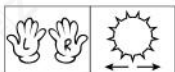

刃径 Flute Diameter		6.0mm
刃长 Flute Length		14.5mm
Grits Size 颗粒度	Coarse C	8002415
	Medium M	8002315
	Fine F	8002215
	Extra Fine XF	8002115

## Cooling – Groove Long Bullet Shape

长刃弧形圆头-冷却槽

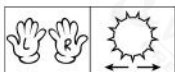

刃径 Flute Diameter		6.0mm
刃长 Flute Length		14.5mm
Grits Size 颗粒度	Coarse C	8007415
	Medium M	8007315
	Fine F	8007215
	Extra Fine XF	8007115



## Conical Shape 弧形尖头

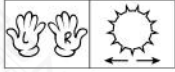

刃径 Flute Diameter		1.6mm	3.0mm	6.6mm
刃长 Flute Length		3mm	7mm	12.7mm
Grits Size 颗粒度	Coarse C	8001433	8001413	8002416
	Medium M	8001333	8001313	8002316
	Fine F	8001233	8001213	8002216
	Extra Fine XF	8001133	8001113	8002116

## Cooling – Groove Conical Shape 弧形尖头-冷却槽

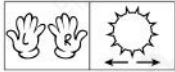

刃径 Flute Diameter		—	—	6.6mm
刃长 Flute Length		—	—	12.7mm
Grits Size 颗粒度	Coarse C	—	—	8007416
	Medium M	—	—	8007316
	Fine F	—	—	8007216
	Extra Fine XF	—	—	8007116

## Ceram Bits – Silicon 小绿磨头-砂石

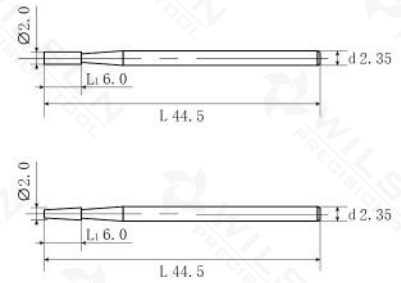
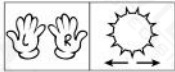

形状 Shape	直筒 Barrel	锥形 Cone
订单编号 Order No.	7101304	7101309

陶瓷磨头



Ceramic Nail B

# Ceramic Nail Bits

陶瓷磨头

# Ceramic Bits Specifications

## 美甲陶瓷磨头规格

Coarseness 齿密度	Ring 色圈
Ultra 四倍 Coarse 特粗齿	4XC
Triple 三倍 Coarse 特粗齿	3XC
Double 两倍 Coarse 特粗齿	XXC
Extra 特粗齿 Coarse	XC
Coarse 粗齿	C
Medium 标准齿	M
Fine 细齿	F
Extra 特细齿 Fine	XF
Double 两倍 Fine 特细齿	XXF
Triple 三倍 Fine 极细齿	3XF

Shank Diameter  
柄径  
2.35mm  
3.175mm



- For Left Hand  
左手
- For Right Hand  
右手
- For Left and Right Hand  
左、右手
- For Left and Right Hand  
左、右手  
Reduced capacity for left hand  
左手使用时切削力下降
- Left Hand Single Rotation  
左手单向打磨
- Right Hand Single Rotation  
右手单向打磨
- Left and Right Hand Dual Rotation  
左、右手双向打磨

Color:  
颜色

White	Black	Pink	Yellow	Blue
白色	黑色	粉色	黄色	蓝色

\* 本样本册所有编号默认列示白色陶瓷，除特殊规格外。  
\* All numbers in this catalogue are listed as White Ceramic by default, except for special specifications.

\* 特殊规格磨头，均可定制。  
\* Grinding heads of special specifications can be customized.

### Large Barrel Bits 6.60mm直筒平头

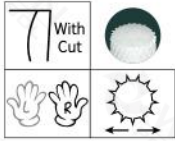
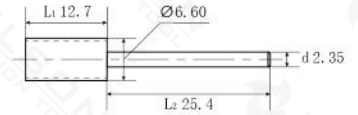

密度 Coarseness	Ultra Coarse 4XC	Triple Coarse 3XC	Double Coarse XXC	Extra Coarse XC	Coarse C	Medium M	Fine F	Extra Fine XF	Double Fine XXF	Triple Fine 3XF
订单编号 Order No.	6100077	6100078	6100079	6100080	6100081	6100082	6100083	6100084	6100085	6100127

### Large Barrel Bits (Chamfer) 6.60mm直筒平头 (倒角)

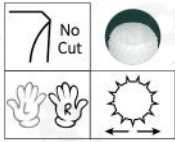
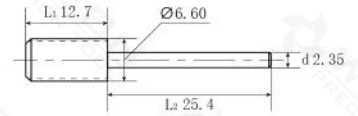

密度 Coarseness	Ultra Coarse 4XC	Triple Coarse 3XC	Double Coarse XXC	Extra Coarse XC	Coarse C	Medium M	Fine F	Extra Fine XF	Double Fine XXF	Triple Fine 3XF
订单编号 Order No.	6100560	6100561	6100562	6100563	6100564	6100565	6100566	6100567	6100568	6100569

### Crystal Large Barrel Bits 6.60mm带钻直筒平头

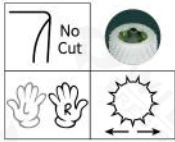
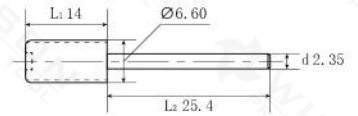

密度 Coarseness	Ultra Coarse 4XC	Triple Coarse 3XC	Double Coarse XXC	Extra Coarse XC	Coarse C	Medium M	Fine F	Extra Fine XF	Double Fine XXF
订单编号 Order No.	6100471	6100472	6100473	6100474	6100475	6100476	6100477	6100478	6100479

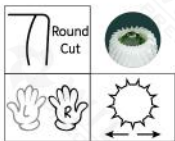
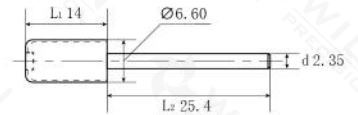

### Crystal Large Barrel Bits (R Cut) 6.60mm带钻直筒平头 (R角)

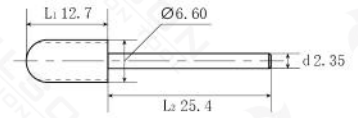

密度 Coarseness	Ultra Coarse 4XC	Triple Coarse 3XC	Double Coarse XXC	Extra Coarse XC	Coarse C	Medium M	Fine F	Extra Fine XF	Double Fine XXF
订单编号 Order No.	6100369	6100370	6100371	6100372	6100373	6100374	6100375	6100376	6100377

### Large Barrel Smooth Top Bits 6.60mm直筒光头



 No Cut 								
	密度 Coarseness	Triple Coarse 3XC	Double Coarse XXC	Extra Coarse XC	Coarse C	Medium M	Fine F	Extra Fine XF
订单编号 Order No.	6100098	6100099	6100100	6100101	6100102	6100103	6100104	6100105

### Large Rounded Top Bits 6.60mm直筒球头

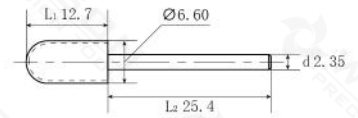

 Round Cut 							
	密度 Coarseness	Triple Coarse 3XC	Double Coarse XXC	Extra Coarse XC	Coarse C	Medium M	Fine F
订单编号 Order No.	6100058	6100059	6100060	6100061	6100062	6100063	6100064

### Small Barrel Bits 6.0mm直筒平头

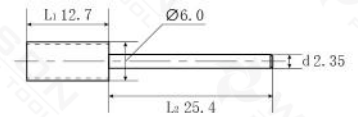

 With Cut 									
	密度 Coarseness	Ultra Coarse 4XC	Triple Coarse 3XC	Double Coarse XXC	Extra Coarse XC	Coarse C	Medium M	Fine F	Extra Fine XF
订单编号 Order No.	6100087	6100088	6100089	6100090	6100091	6100092	6100093	6100094	6100095

### Small Barrel Bits (Chamfer) 6.0mm直筒平头 (倒角)

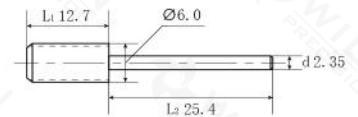

 No Cut 									
	密度 Coarseness	Ultra Coarse 4XC	Triple Coarse 3XC	Double Coarse XXC	Extra Coarse XC	Coarse C	Medium M	Fine F	Extra Fine XF
订单编号 Order No.	6100834	6100835	6100836	6100837	6100838	6100839	6100840	6100841	6100842

### Small Barrel Smooth Top Bits 6.0mm直筒光头

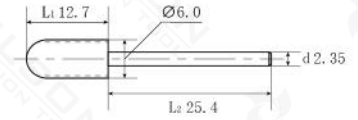

	Triple Coarse 3XC	Double Coarse XXC	Extra Coarse XC	Coarse C	Medium M	Fine F	Extra Fine XF	Double Fine XXF
密度 Coarseness								
订单编号 Order No.	6100022	6100023	6100024	6100025	6100026	6100027	6100028	6100029

### Small Rounded Top Bits 6.0mm直筒球头

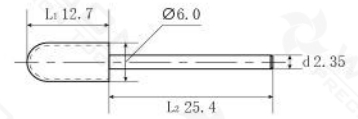

	Triple Coarse 3XC	Double Coarse XXC	Extra Coarse XC	Coarse C	Medium M	Fine F	Extra Fine XF
密度 Coarseness							
订单编号 Order No.	6100108	6100109	6100110	6100111	6100112	6100113	6100114

### 3 in 1 Bits (Straight Cut) 三合一(直槽齿)

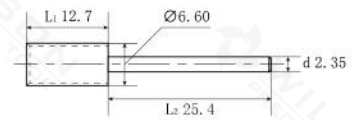

	Triple Coarse 3XC	Double Coarse XXC	Extra Coarse XC	Coarse C	Medium M	Fine F	Extra Fine XF	Double Fine XXF
密度 Coarseness								
订单编号 Order No.	6100908	6100909	6100910	6100911	6100912	6100913	6100914	6100915

### 7.0mm 5 in 1 Bits (Straight Cut) 7.0mm五合一(直槽齿)

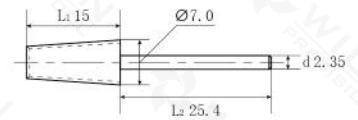

	Triple Coarse 3XC	Double Coarse XXC	Extra Coarse XC	Coarse C	Medium M	Fine F	Extra Fine XF	Double Fine XXF
密度 Coarseness								
订单编号 Order No.	6100865	6100866	6100867	6100868	6100869	6100870	6100871	6100872

### 7.0mm 5 in 1 Bits (Cross Cut)

7.0mm五合一(交叉齿)

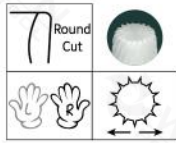
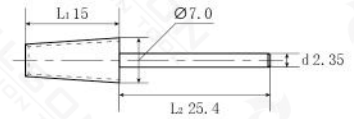

密度 Coarseness	Extra Coarse XC	Coarse C	Medium M	Fine F
订单编号 Order No.	6101005	6101006	6101007	6101008

### Large Tapered Barrel Bits

6.6mm锥形平头

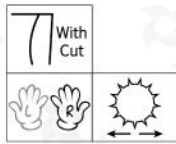
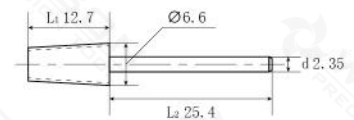

密度 Coarseness	Double Coarse XXC	Extra Coarse XC	Coarse C	Medium M	Fine F	Extra Fine XF
订单编号 Order No.	6100513	6100514	6100123	6100124	6100125	6100515

### Small Cone Bits

3.1mm锥形球头

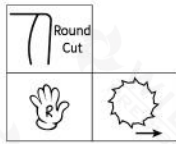
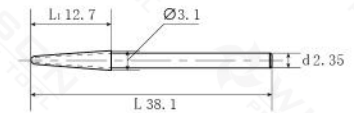

密度 Coarseness	Coarse C	Medium M
订单编号 Order No.	6000286	6000287

### Cone Bits

4.0mm锥形球头

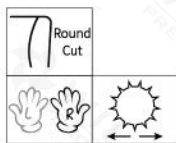
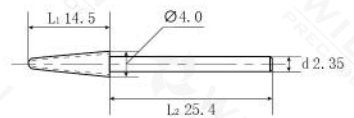

密度 Coarseness	Extra Coarse XC	Coarse C	Medium M	Fine F
订单编号 Order No.	6100364	6100365	6100366	6100367

## Big Cone Bits 6.0mm锥形球头

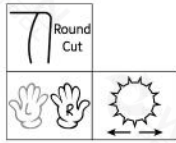
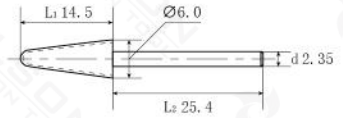

密度 Coarseness	Extra Coarse XC	Coarse C	Medium M	Fine F
订单编号 Order No.	6100493	6100494	6100495	6100496

## Volcano Bits 7.0mm火山形

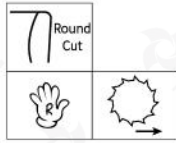
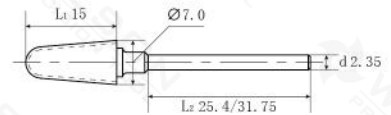

密度 Coarseness	Triple Coarse 3XC	Double Coarse 2XC	Extra Coarse XC	Coarse C	Medium M	Fine F	Extra Fine XF	
订单编号 Order No.	Shank a 25.4mm	6101589	6101590	6101591	6101592	6101593	6101594	6101595
	Shank c 31.75mm	6101599	6101600	6101601	6101602	6101603	6101604	6101605

## Volcano Bits (2 Way) 7.0mm火山形 (双向)

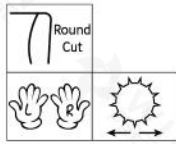
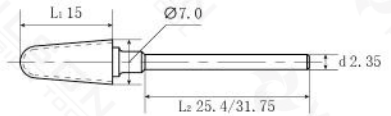

密度 Coarseness	Triple Coarse 3XC	Double Coarse 2XC	Extra Coarse XC	Coarse C	Medium M	Fine F	Extra Fine XF	Double Fine XXF	
订单编号 Order No.	Shank a 25.4mm	6101509	6101510	6101511	6101512	6101513	6101514	6101515	6101516
	Shank c 31.75mm	6101519	6101520	6101521	6101522	6101523	6101524	6101525	6101526

## Typhoon Bits 6.0mm台风形

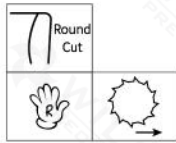
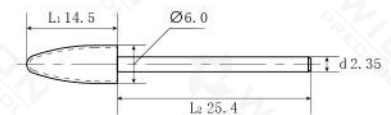

密度 Coarseness	Extra Coarse XC	Coarse C	Medium M	Fine F
订单编号 Order No.	6100810	6100811	6100812	6100813



### Typhoon Bits (2 Way) 6.0mm台风形 (双向)

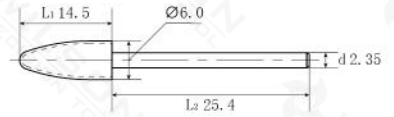

 Round Cut  							
	密度 Coarseness	Double Coarse XXC	Extra Coarse XC	Coarse C	Medium M	Fine F	Extra Fine XF
订单编号 Order No.	6100886	6100887	6100888	6100889	6100890	6100891	6100892



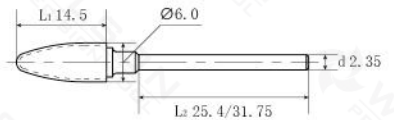







### Flame Bits 6.0mm火炬状



 Round Cut  							
	密度 Coarseness	Extra Coarse XC	Coarse C	Medium M	Fine F	Extra Fine XF	Double Fine XXF
订单编号 Order No.	Shank a 25.4mm	6101652	6101653	6101654	6101655	6101656	6101657
	Shank c 31.75mm	6101662	6101663	6101664	6101665	6101666	6101667

### Upgrade Flame Bits 6.0mm火炬状 (升级版-金柄)



 Round Cut  							
	密度 Coarseness	Double Coarse XXC	Extra Coarse XC	Coarse C	Medium M	Fine F	Extra Fine XF
订单编号 Order No.	6101856	6101857	6101858	6101859	6101860	6101861	6101862

### Long Flame Bits 6.0mm长刃火炬状

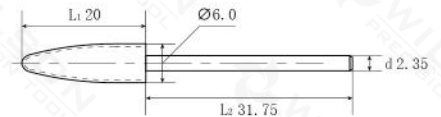

 Round Cut  			
	密度 Coarseness	Coarse C	Medium M
订单编号 Order No.	6100181	6100182	6100183

### Under Nail Cleaner Bits 针状平头



	Coarse C	Medium M	Fine F	Extra Fine XF
密度 Coarseness				
订单编号 Order No.	6000034	6000035	6000036	6000469

### Buffer Bits (Diamond Cut) 本甲刻磨磨头 (钻石齿)

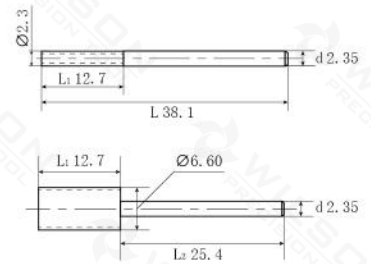

	2.3	6.6
刃径 Dmm		
订单编号 Order No.	6000128	6100129

### Round Bits 小直筒球头

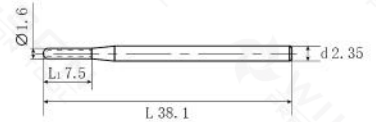

	Coarse C	Medium M	Fine F	Extra Fine XF	Double Fine XXF
密度 Coarseness					
订单编号 Order No.	6000031	6000032	6000033	6000231	6000253

### Upgrade Round Bits 小直筒球头 (升级版)

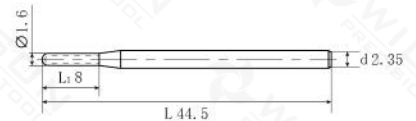

	Medium M
密度 Coarseness	
订单编号 Order No.	6000948

## Polygon Bits 多边形磨头

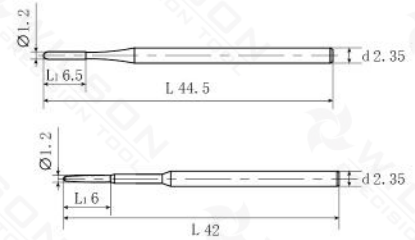
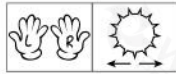

形状 Shape	七边形 Septangle	八边形 Octagon
订单编号 Order No.	6000233	6000232

## Mini Polygon Bits 迷你多边形磨头

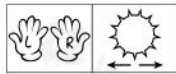

形状 Shape	迷你八边形 Mini Octagon
订单编号 Order No.	6000906

## Cuticle Clean Bits 角质清洁磨头

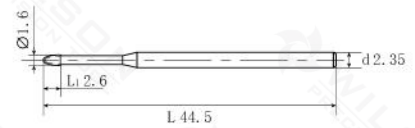
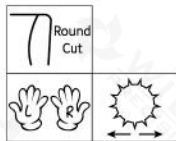

密度 Coarseness	Extra Coarse XC	Coarse C	Medium M	Fine F
订单编号 Order No.	6000610	6000510	6000362	6000361

## Ball Shape Bits (Cross Cut) 球形(交叉齿)

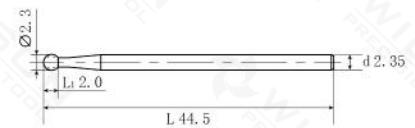
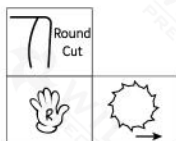

刃径 Dmm	2.3	2.3	2.3	3.0	3.0	3.0
订单编号 Order No.	6000706	6000707	6000708	6001445	6001446	6001447

足部磨头



# Pedicure Bits

足部磨头



Pedicure Bits

**Ball Shape Bits – Pedicure**  
5.0mm球头



Round Cut 							
	刃径 Dmm	5.0	3.0	4.0	5.0	6.0	7.0
订单编号 Order No.	1300566	6000925	6100926	6100927	6100928	6100929	6100930

**Flame Shape Bits – Pedicure**  
火炬状

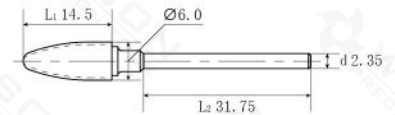

Round Cut 	
	密度 Coarseness
订单编号 Order No.	1100258

**Big Rounded Top Bits – Pedicure**  
8.0mm直筒球头

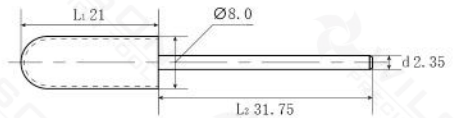

Round Cut 	
	密度 Coarseness
订单编号 Order No.	1101017

**Big Flame Shape Bits – Pedicure**  
8.0mm火炬状

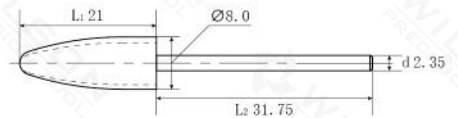

Round Cut 	
	密度 Coarseness
订单编号 Order No.	1101024

### Hollow Cutter Bits – Pedicure 鸡眼刀 (不带齿)

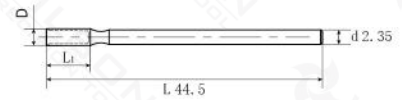

刃径 Dmm	1.8	2.3	2.7	3.0
订单编号 Order No.	1300559	1300560	1300561	1300562

### Hollow Cutter Toothed Bits – Pedicure 鸡眼刀 (带齿)

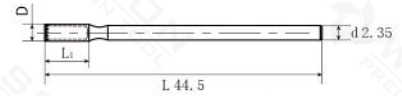

刃径 Dmm	1.8	2.3	2.7	3.0
订单编号 Order No.	1300555	1300556	1300557	1300558

### Flame Shape Bits – Pedicure 6.0mm火炬状

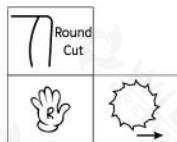
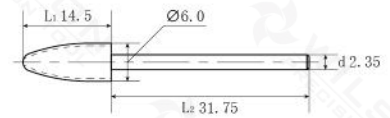

密度 Coarseness	Coarse C	Medium M	Fine F
订单编号 Order No.	6100051	6100052	6100053

### Big Rounded Top Bits – Pedicure 8.0mm直筒球头

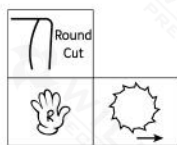
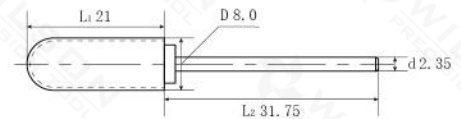

密度 Coarseness	Coarse C
订单编号 Order No.	6101044

**Big Flame Shape Bits – Pedicure**  
8.0mm火炬状

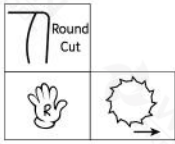
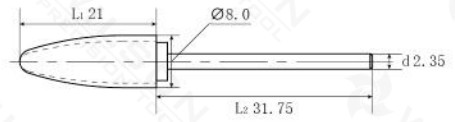

密度 Coarseness	Fine F
订单编号 Order No.	6101051

**10.0mm Diamond Bits – Pedicure**  
10.0mm金刚砂

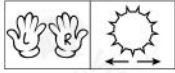
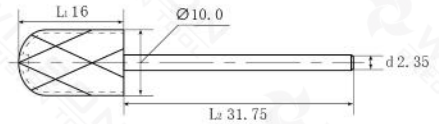

密度 Coarseness	Coarse C	Medium M	Fine F
订单编号 Order No.	A029011	A029012	A029013

**13.0mm Diamond Bits – Pedicure**  
13.0mm金刚砂

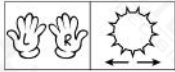
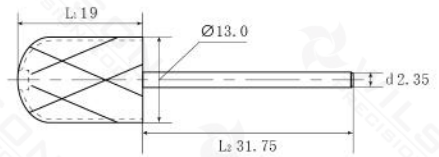

密度 Coarseness	Coarse C	Medium M	Fine F
订单编号 Order No.	A029001	A029002	A029003

**Zirconia Ceramic Foot File – Pedicure**  
锆石足部护理

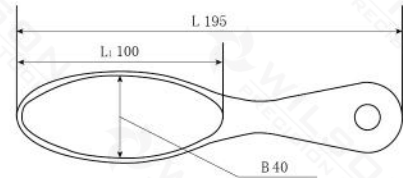

密度 Coarseness	Coarse C
订单编号 Order No.	A994203



美甲附件



Nail Accessories

# Nail Accessories

美甲附件

**Disc Mandrel – Flat**  
碟形圆轴-平面



直径 D mm	15 mm	20 mm	20 mm	25 mm	25 mm	25 mm
编号 Order No.	8600023	8600017	8600021	8600001	8600007	8600005

**Disc Mandrel – Curve**  
碟形圆轴-弧面



直径 D mm	20 mm	20 mm	25 mm	25 mm	25 mm
编号 Order No.	8600018	8600022	8600002	8600008	8600006

**Sanding Paper**  
砂片

颜色 Colour	[Yellow circles]			[Grey circles]			[Blue circles]			[Light Green circles]			
直径 D mm	15 mm	20 mm	25 mm	15 mm	20 mm	25 mm	15 mm	20 mm	25 mm	15 mm	20 mm	25 mm	
Grits Size 颗粒度	80#	A110211	A110521	A110011	A110221	A110531	A110021	A110201	A110511	A110001	A110231	A110541	A110031
	120#	A110212	A110522	A110012	A110222	A110532	A110022	A110202	A110512	A110002	A110232	A110542	A110032
	180#	A110213	A110523	A110013	A110223	A110533	A110023	A110203	A110513	A110003	A110233	A110543	A110033
	240#	A110214	A110524	A110014	A110224	A110534	A110024	A110204	A110514	A110004	A110234	A110544	A110034

**Zirconia Ceramic Mini File**  
锆石迷你锉条



## Sanding Band Mandrel 砂圈轴芯



材质 Material	钨钢 Carbide		不锈钢 Stainless Steel	
编号 Order No.	1100149	1101679	1100551	1100549

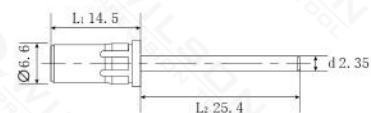
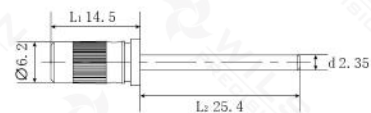
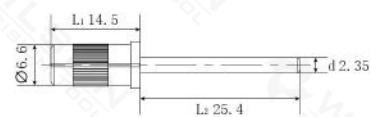

## Sanding Band 砂圈

密度 Coarseness		Extra Coarse XC	Coarse C	Medium M	Fine F	
编号 Order No.	棕色 Brown	A050001	A050005	A050009	A050013	
	黑色 Black	A050017	A050021	A050025	A050029	
	斑马白 Zebra	A050201	A050205	A050209	A050213	
	绿色 Green	A050100	A050104	A050108	A050112	



25pcs

100pcs

1000pcs

## Bag 磨头收纳包



A120101



A120102



A120103



A120104



A120105



A120106

## Brush 刷子



A100001



A100102



A100201



A100401









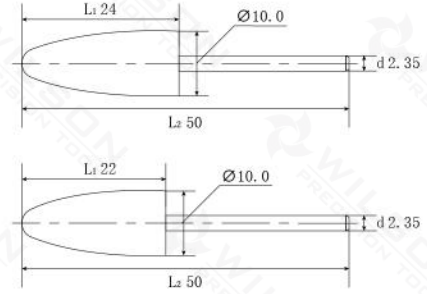





A100402

**Polisher**  
抛光磨头

				
颗粒度 Grits Size		180#	320#	600#
订单编号 Order No.		7006601	7003401	7003301



密度 Coarseness	硅胶磨头 Silicone Polishers		
Coarse C			
编号 Order No.	A030001	A030011	A030021
Medium M			
编号 Order No.	A030002	A030012	A030022
Fine F			
编号 Order No.	A030003	A030013	A030023
Extra Fine XF			
编号 Order No.			A030024

密度 Coarseness	硅胶磨头 Silicone Polishers		橡胶磨头 Rubber Polishers	
Coarse C				
编号 Order No.	A030031	A030041	A040011	A040001
Medium M				
编号 Order No.	A030032	A030042	A040012	A040002
Fine F				
编号 Order No.	A030033	A030043	A040013	A040003
Extra Fine XF				
编号 Order No.	A030034	A030044	A040014	A040004

**Sanding Cap**  
砂帽

颜色 Color	尺寸 Size	密度 Grit	尺寸 Dia	Φ5mm	Φ7mm	Φ10mm	Φ13mm	Φ16mm
			形状 Shape					
棕色 Brown	Coarse C			A060011	A060061	A060111	A060161	A060211
		Medium M		A060021	A060071	A060121	A060171	A060221
		Fine F		A060031	A060081	A060131	A060181	A060231

**Rubber Mandrel**  
橡胶轴

Shank Length=40mm ; Shank Dia.=Φ2.35 mm

尺寸 Size	Φ5mm	Φ7mm	Φ10mm	Φ13mm	Φ16mm
形状 Shape					
RoundedTop	A069951	A069952	A069953	A069954	A069955

**Sanding Caps Size:**

- Φ 5 mm \* 11 mm
- Φ 7 mm \* 13 mm
- Φ 10 mm \* 15 mm
- Φ 13 mm \* 19 mm
- Φ 16 mm \* 26 mm

# Reference Form

## 产品索引

Order No.	Page	Order No.	Page	Order No.	Page	Order No.	Page	Order No.	Page	Order No.	Page	Order No.	Page
<b>Cabide Naf Bits 超硬磨头</b>													
1100001	8	1100179	6	1100582	7	1100926	12	1300714	23	1102130	27	8000231	34
1100002	8	1100180	6	1100583	7	1100955	10	1300715	23	1102131	27	8000236	35
1100003	8	1100181	6	1100584	7	1100956	10	1300716	23	1102132	27	8000237	35
1100004	8	1100182	6	1100586	7	1100957	10	1300884	23	1102133	27	8000238	35
1100005	8	1100183	6	1100587	7	1100958	10	1300897	19	1102134	27	8000239	36
1100006	8	1100184	6	1100588	7	1100959	10	1300929	18	1102160	28	8000240	36
1100007	5	1100186	8	1100589	7	1100960	10	1300930	18	1102161	28	8000241	36
1100008	5	1100187	8	1100590	7	1100961	10	1300931	18	1102162	28	8000242	36
1100009	5	1100188	8	1100591	7	1100962	10	1300951	22	1102163	28	8000243	36
1100010	5	1100189	8	1100592	7	1100997	11	1300952	22	1102164	28	8000244	36
1100011	5	1100190	8	1100593	7	1100998	11	1300953	22			8000247	36
1100012	5	1100191	8	1100594	7	1100999	11	1300993	19	<b>Diamond Bits 电鍍超硬磨头</b>		8000248	36
1100013	5	1100229	14	1100629	15	1101000	11	1300994	19	7101309	38	8000249	36
1100014	5	1100230	14	1100630	15	1101001	11	1301079	19	8000101	33	8000250	36
1100015	5	1100231	14	1100631	15	1101002	11	1301080	19	8000103	33	8000257	35
1100016	5	1100251	17	1100633	15	1101003	11	1301099	19	8000104	33	8000262	37
1100020	6	1100276	13	1100634	15	1101004	11	1301100	19	8000105	33	8000263	34
1100021	6	1100277	13	1100635	15	1101058	11	1301203	21	8000106	33	8000264	33
1100022	6	1100278	13	1100638	16	1101059	11	1301239	20	8000107	33	8000265	33
1100023	6	1100279	13	1100639	16	1101060	11	1301240	20	8000108	33	8000267	37
1100024	6	1100321	6	1100640	16	1101061	11	1301242	19	8000109	33	8000268	35
1100025	6	1100322	5	1100641	16	1101062	11	1301653	22	8000110	33	8000301	33
1100026	6	1100325	9	1100642	16	1101684	11	1301654	22	8000111	33	8000303	33
1100027	6	1100401	5	1100643	16	1101685	11	1301655	22	8000112	33	8000304	33
1100028	6	1100402	5	1100644	16	1101686	11	1301656	22	8000113	33	8000305	33
1100029	6	1100403	5	1100648	15	1101687	11	1301657	22	8000114	33	8000306	33
1100033	8	1100404	5	1100649	15	1101688	11	1301681	21	8000115	33	8000307	33
1100035	8	1100405	5	1100650	15	1101753	24	1301719	20	8000116	33	8000308	33
1100037	9	1100406	5	1100651	15	1101754	24	1301748	18	8000117	33	8000309	33
1100038	9	1100407	5	1100652	15	1101755	24	1302149	14	8000119	34	8000310	33
1100039	9	1100408	5	1100653	15	1101756	24	1302150	14	8000120	34	8000311	33
1100040	9	1100409	5	1100654	15	1101806	6	1302155	13	8000121	34	8000312	33
1100041	9	1100411	5	1100678	10	1101807	6	1302156	13	8000122	34	8000313	33
1100042	9	1100412	5	1100679	10	1101808	6	1302157	13	8000123	34	8000314	33
1100043	9	1100413	5	1100680	10	1101887	12	1302176	21	8000124	34	8000315	33
1100044	9	1100414	5	1100681	10	1101888	12	1302383	12	8000125	34	8000316	33
1100045	9	1100415	5	1100682	10	1101932	12	1302384	12	8000126	34	8000317	33
1100049	9	1100416	5	1100698	5	1102085	6	1302385	12	8000127	34	8000319	34
1100050	9	1100417	5	1100699	7	1102086	6	1302386	12	8000128	34	8000320	34
1100051	9	1100418	5	1100700	7	1102087	6	1302387	12	8000129	34	8000321	34
1100055	6	1100419	5	1100701	7	1102088	6	1302446	20	8000130	34	8000322	34
1100056	6	1100431	5	1100702	7	1102089	6	1302450	20	8000131	34	8000323	34
1100057	6	1100432	5	1100703	7	1102090	6	1302806	22	8000136	35	8000324	34
1100061	7	1100433	5	1100704	7	1102381	12	1341643	23	8000137	35	8000325	34
1100062	7	1100434	5	1100705	7	110534	15	1341644	23	8000138	35	8000326	34
1100063	7	1100435	5	1100706	7	110535	15	1341645	23	8000139	36	8000327	34
1100066	6	1100436	5	1100707	7	110536	15	1341646	23	8000140	36	8000328	34
1100068	6	1100437	5	1100708	7	110537	15	1341647	23	8000141	36	8000329	34
1100069	6	1100438	5	1100709	7	110538	15			8000142	36	8000330	34
1100073	8	1100439	5	1100710	17	110544	16	<b>SC Bits 超硬可削磨头</b>		8000143	36	8000331	34
1100074	8	1100440	5	1100711	17	110545	16	1100973	28	8000144	36	8000336	35
1100075	8	1100441	5	1100712	17	110546	16	1100974	28	8000147	36	8000337	35
1100082	23	1100442	16	1100713	15	110547	16	1100975	28	8000148	36	8000338	35
1100083	23	1100464	14	1100733	15	1107991	15	1100976	28	8000149	36	8000339	36
1100084	23	1100465	14	1100734	15	1300079	18	1101037	29	8000150	36	8000340	36
1100085	24	1100467	17	1100735	15	1300080	18	1101038	29	8000157	35	8000341	36
1100086	24	1100468	17	1100736	15	1300081	18	1101039	29	8000162	37	8000342	36
1100087	24	1100469	17	1100750	16	1300100	13	1101072	27	8000163	34	8000343	36
1100088	12	1100470	17	1100751	16	1300101	13	1101073	27	8000164	33	8000344	36
1100089	12	1100476	16	1100752	16	1300102	13	1101074	27	8000165	33	8000347	36
1100090	12	1100486	16	1100753	16	1300106	13	1101075	27	8000167	37	8000348	36
1100094	14	1100488	16	1100754	16	1300107	13	1101076	27	8000168	35	8000349	36
1100095	14	1100489	16	1100755	16	1300108	13	1101082	27	8000201	33	8000350	36
1100096	14	1100490	16	1100756	16	1300112	18	1101083	27	8000203	33	8000357	35
1100119	16	1100491	16	1100858	10	1300113	18	1101084	27	8000204	33	8000362	37
1100120	16	1100492	16	1100859	10	1300114	18	1101085	27	8000205	33	8000363	34
1100121	16	1100512	17	1100860	10	1300126	15	1101086	27	8000206	33	8000364	33
1100122	16	1100513	17	1100861	10	1300127	15	1101244	28	8000207	33	8000365	33
1100132	17	1100514	17	1100862	10	1300128	15	1101245	28	8000208	33	8000367	37
1100133	17	1100515	17	1100863	10	1300141	22	1101246	28	8000209	33	8000368	35
1100134	17	1100516	17	1100864	10	1300142	22	1101247	28	8000210	33	8000401	33
1100135	24	1100517	17	1100865	10	1300143	22	1101248	28	8000211	33	8000403	33
1100136	24	1100524	15	1100866	10	1300147	19	1101264	28	8000212	33	8000404	33
1100137	24	1100525	15	1100867	10	1300148	20	1101265	28	8000213	33	8000405	33
1100138	24	1100526	15	1100868	10	1300226	13	1101266	28	8000214	33	8000406	33
1100139	24	1100527	15	1100869	10	1300238	13	1101267	28	8000215	33	8000407	33
1100140	24	1100529	16	1100870	10	1300250	21	1101268	28	8000216	33	8000408	33
1100165	6	1100530	16	1100871	10	1300391	22	1101361	29	8000217	33	8000409	33
1100166	6	1100531	16	1100873	16	1300395	15	1101362	29	8000219	34	8000410	33
1100167	6	1100532	16	1100874	16	1300398	21	1101363	29	8000220	34	8000411	33
1100168	6	1100540	15	1100875	16	1300400	21	1101364	29	8000221	34	8000412	33
1100169	6	1100541	15	1100895	10	1300504	17	1101377	29	8000222	34	8000413	33
1100170	6	1100542	15	1100910	11	1300506	20	1101378	29	8000223	34	8000414	33
1100172	7	1100543	15	1100911	11	1300507	20	1101379	29	8000224	34	8000415	33
1100173	7	1100576	7	1100912	11	1300553	23	1101380	29	8000225	34	8000416	33
1100174	7	1100577	7	1100913	11	1300554	23	1101935	27	8000226	34	8000417	33
1100175	7	1100578	7	1100914	11	1300575	17	1101936	27	8000227	34	8000419	34
1100176	7	1100579	7	1100915	11	1300711	18	1101937	27	8000228	34	8000420	34
1100177	7	1100580	7	1100916	11	1300712	19						

Order No.	Page
8002318	36
8002319	35
8002403	33
8002404	33
8002405	35
8002409	35
8002412	36
8002415	37
8002416	38
8002418	36
8002419	35
8005105	33
8005106	33
8005107	33
8005108	33
8005109	33
8005110	33
8005111	33
8005112	33
8005113	33
8005114	33
8005115	33
8005116	33
8005117	33
8005120	34
8005121	34
8005122	34
8005123	34
8005125	34
8005126	34
8005127	34
8005128	34
8005129	34
8005130	34
8005131	34
8005136	35
8005137	35
8005138	35
8005141	36
8005142	36
8005143	36
8005144	36
8005147	36
8005148	36
8005149	36
8005150	36
8005157	35
8005163	34
8005164	33
8005165	33
8005168	35
8005205	33
8005206	33
8005207	33
8005208	33
8005209	33
8005210	33
8005211	33
8005212	33
8005213	33
8005214	33
8005215	33
8005216	33
8005217	33
8005220	34
8005221	34
8005222	34
8005223	34
8005225	34
8005226	34
8005227	34
8005228	34
8005229	34
8005230	34
8005231	34
8005236	35
8005237	35
8005238	35
8005241	36
8005242	36
8005243	36
8005244	36
8005247	36
8005248	36
8005249	36
8005250	36
8005257	35
8005263	34
8005264	33
8005265	33

Order No.	Page
8005268	35
8005305	33
8005306	33
8005307	33
8005308	33
8005309	33
8005310	33
8005311	33
8005312	33
8005313	33
8005314	33
8005315	33
8005316	33
8005317	33
8005320	34
8005321	34
8005322	34
8005323	34
8005325	34
8005326	34
8005327	34
8005328	34
8005329	34
8005330	34
8005331	34
8005336	35
8005337	35
8005338	35
8005341	36
8005342	36
8005343	36
8005344	36
8005347	36
8005348	36
8005349	36
8005350	36
8005357	35
8005363	34
8005364	33
8005365	33
8005368	35
8005405	33
8005406	33
8005407	33
8005408	33
8005409	33
8005410	33
8005411	33
8005412	33
8005413	33
8005414	33
8005415	33
8005416	33
8005417	33
8005420	34
8005421	34
8005422	34
8005423	34
8005425	34
8005426	34
8005427	34
8005428	34
8005429	34
8005430	34
8005431	34
8005436	35
8005437	35
8005438	35
8005441	36
8005442	36
8005443	36
8005444	36
8005447	36
8005448	36
8005449	36
8005450	36
8005457	35
8005463	34
8005464	33
8005465	33
8005468	35
8006103	34
8006117	35
8006118	34
8006203	34
8006217	35
8006218	34
8006303	34
8006317	35
8006318	34

Order No.	Page
8006403	34
8006417	35
8006418	34
8007103	33
8007104	33
8007105	35
8007109	35
8007112	36
8007115	37
8007116	38
8007118	36
8007119	35
8007203	33
8007204	33
8007205	35
8007209	35
8007212	36
8007215	37
8007216	38
8007218	36
8007219	35
8007303	33
8007304	33
8007305	35
8007309	35
8007312	36
8007315	37
8007316	38
8007318	36
8007319	35
8007403	33
8007404	33
8007405	35
8007409	35
8007412	36
8007415	37
8007416	38
8007418	36
8007419	35
8101304	38
8101309	38
8202120	34
8202220	34
8202320	34
8202420	34
8207120	34
8207220	34
8207320	34
8207420	34
<b>Ceramic Nail Bits 陶瓷磨头</b>	
6000031	47
6000032	47
6000033	47
6000034	47
6000035	47
6000036	47
6000128	47
6000231	47
6000232	48
6000233	48
6000253	47
6000286	44
6000287	44
6000361	48
6000362	48
6000469	47
6000510	48
6000610	48
6000706	48
6000707	48
6000708	48
6000906	48
6000948	47
6001445	48
6001446	48
6001447	48
6100022	43
6100023	43
6100024	43
6100025	43
6100026	43
6100027	43
6100028	43
6100029	43
6100058	42
6100059	42
6100060	42
6100062	42
6100063	42

Order No.	Page
6100064	42
6100077	41
6100078	41
6100079	41
6100080	41
6100081	41
6100082	41
6100083	41
6100084	41
6100085	41
6100087	42
6100088	42
6100089	42
6100090	42
6100091	42
6100092	42
6100093	42
6100094	42
6100095	42
6100098	42
6100099	42
6100100	42
6100101	42
6100102	42
6100103	42
6100104	42
6100105	42
6100108	43
6100109	43
6100110	43
6100111	43
6100112	43
6100113	43
6100114	43
6100123	44
6100124	44
6100125	44
6100127	41
6100129	47
6100181	46
6100182	46
6100183	46
6100364	44
6100365	44
6100366	44
6100367	44
6100369	41
6100370	41
6100371	41
6100372	41
6100373	41
6100374	41
6100375	41
6100376	41
6100377	41
6100471	41
6100472	41
6100473	41
6100474	41
6100475	41
6100476	41
6100477	41
6100478	41
6100479	41
6100493	45
6100494	45
6100495	45
6100496	45
6100513	44
6100514	44
6100515	44
6100560	41
6100561	41
6100562	41
6100563	41
6100564	41
6100565	41
6100566	41
6100567	41
6100568	41
6100569	41
6100810	45
6100811	45
6100812	45
6100813	45
6100834	42
6100835	42
6100836	42
6100837	42
6100838	42

Order No.	Page
6100839	42
6100840	42
6100841	42
6100842	42
6100865	43
6100866	43
6100867	43
6100868	43
6100869	43
6100870	43
6100871	43
6100872	43
6100886	46
6100887	46
6100888	46
6100889	46
6100890	46
6100891	46
6100892	46
6100908	43
6100909	43
6100910	43
6100911	43
6100912	43
6100913	43
6100914	43
6100915	43
6101005	44
6101006	44
6101007	44
6101008	44
6101509	45
6101510	45
6101511	45
6101512	45
6101513	45
6101514	45
6101515	45
6101516	45
6101519	45
6101520	45
6101521	45
6101522	45
6101523	45
6101524	45
6101524	45
6101525	45
6101526	45
6101589	45
6101590	45
6101591	45
6101592	45
6101593	45
6101594	45
6101595	45
6101599	45
6101600	45
6101601	45
6101602	45
6101603	45
6101604	45
6101605	45
6101652	46
6101653	46
6101654	46
6101655	46
6101656	46
6101657	46
6101662	46
6101663	46
6101664	46
6101665	46
6101666	46
6101667	46
6101856	46
6101857	46
6101858	46
6101859	46
6101860	46
6101861	46
6101862	46
<b>Pedicure Bits 足部磨头</b>	
1100258	51
1101017	51
1101024	51
1300555	52
1300556	52
1300557	52
1300558	52
1300559	52
1300560	52

Order No.	Page
1300561	52
1300562	52
1300566	51
6000925	51
6000926	51
6000927	51
6000928	51
6000929	51
6000930	51
6100051	52
6100052	52
6100053	52
6101044	52
6101051	53
A029001	53
A029002	53
A029003	53
A029011	53
A029012	53
A029013	53
A994203	53
<b>Nail Accessories 美甲附件</b>	
A993241	55
A993242	55
A993243	55
8600023	55
8600017	55
8600021	55
8600001	55
8600007	55
8600005	55
8600018	55
8600022	55
8600002	55
8600008	55
8600006	55
A110211	55
A110212	55
A110213	55
A110214	55
A110521	55
A110522	55
A110523	55
A110524	55
A110011	55
A110012	55
A110013	55





上海惠而顺精密工具股份有限公司  
Shanghai WELL-SUN Precision Tool Co., Ltd.

上海惠而顺精工科技发展有限公司  
Shanghai WILSON Precision Technology Co., Ltd.

地址 Add: 上海市宝山区真陈路868号3幢厂房  
#3 Workshop, No. 868 Zhenchen Rd.  
Baoshan Urban Industry Park  
Shanghai, 200444 P.R.China

邮箱E-mail: [sales@wilsonprecisiontool.com](mailto:sales@wilsonprecisiontool.com)

网址Web : [www.wilsonprecisiontool.com](http://www.wilsonprecisiontool.com)

惠而顺精密工具(美国)有限公司

WILSON Precision Tool USA, Inc

Add: 329W.18th Street, suite 309

Chicago, IL 60616 USA

Tel : (312)243-6680

Website: [www.wilsonprecisiontool.com](http://www.wilsonprecisiontool.com)

